



**item**

**The ergonomic work bench system.**

New Products Autumn 2010



## Ergonomics in its purest form.

Your own customised work bench configured from our broad, standardised portfolio – fast, flexible, economical and ergonomic. Whether integrated into production lines, as a module for production islands or as an individual work bench, our new item work bench range will always have the right solution for all your needs! All tables are height adjustable, with electrical systems available on request. The basic configuration (table design and table top) alone offers a range of 80 table variants. What's more, these variants can be combined with uprights, overhangs and a whole range of innovative accessories.

### 04 The work benches

#### 10 Work bench E

Extremely easy-to-operate work bench with electrical height adjustment. Available in three widths and two depths. Table tops available in 25, 30 and 40 mm variants and with ESD protection. Changing between a sitting and standing work bench couldn't be easier.



**12** Work bench 4 E  
Work bench with electrical height adjustment, exceptional stability and load-carrying capacity thanks to high torsional rigidity. 1200, 1500 or 1800 mm wide and 600 or 750 mm deep. Flexibility of changing between a sitting and standing work bench.

**14** Work bench F  
Work bench with infinite, manual height adjustment. 1200, 1500 or 1800 mm wide and 600 or 750 mm deep. Available in four different table top qualities. Particularly easy to integrate into production lines.

**16** Work bench TRIGO F  
Triangular work bench with infinite, manual height adjustment. Use in production islands delivers ergonomic benefits. Available in four different table top qualities.

**18** Working surfaces  
Working surfaces available in six sizes and four materials/thicknesses – from 1200 x 600 to 1800 x 750 mm and from 25 to 40 mm thick – plastic coated, HPL, HPL with ESD conductivity and beech multi-ply.



The optimum space for exceptional work.

## The new item work bench system – work benches for assembly, maintenance, repair and testing systems

item has been designing customised working environments and work benches since it first developed the MB Building Kit System 30 years ago. This extensive know-how has resulted in a wide-ranging standard portfolio for work benches.

**The benefits** – the new work bench system is fully compatible with the MB Building Kit System. When it comes to equipping your work bench, you have our full range at your disposal – including elements for integrating work benches into existing production lines.

Four basic table variants, a range of working surfaces in various sizes and the right accessories for any application. All you need to do is take your pick!

Design your own customised work benches for the future based on standardised item components – the fast and most economical solution!



1984



1992



1993



1995



2000



### Key features of the new item work bench system

Ergonomic and cost-effective – every table is height adjustable, with electrical height adjustment available as an option.

Modular design – configure your own customised work bench in next to no time from a range of possible variants.

item work benches are based on the MB Building Kit System. As a result, they are exceptionally flexible when it comes to integrating them into production processes and retrofitting solutions.

### The right solution for all your needs – the diversity of the item work bench system

item brings you new, innovative solutions for:

- Supplying your work benches with information, power and electronic data,
- Work bench lighting,
- Pivot Arms for the ergonomic provision of small parts and tools,
- A wide range of ESD accessories,
- A diverse range of fastening systems for tools and PCs.

Ensuring you always have the right equipment for all your needs!



[workbench.item24.com](http://workbench.item24.com)

### Simple table configuration makes product selection easy

Choosing the right product couldn't be easier – simply log into our online Product Configurator or use the form at the back of this catalogue.

Select your Table Frame and choose from three widths and two depths. You have the option of adding a table Upright and Overhang to create the optimum space and ergonomic handling area for your work bench.

Pick the working surface and optional accessories that most suit your needs and that's it – your ideal item work bench!

Includes full CAD integration: Transfer your table configuration directly to your CAD system for production planning and designing customised connecting structures.

Your configuration is sent to us online and you will receive a direct response complete with offer from your item partner.

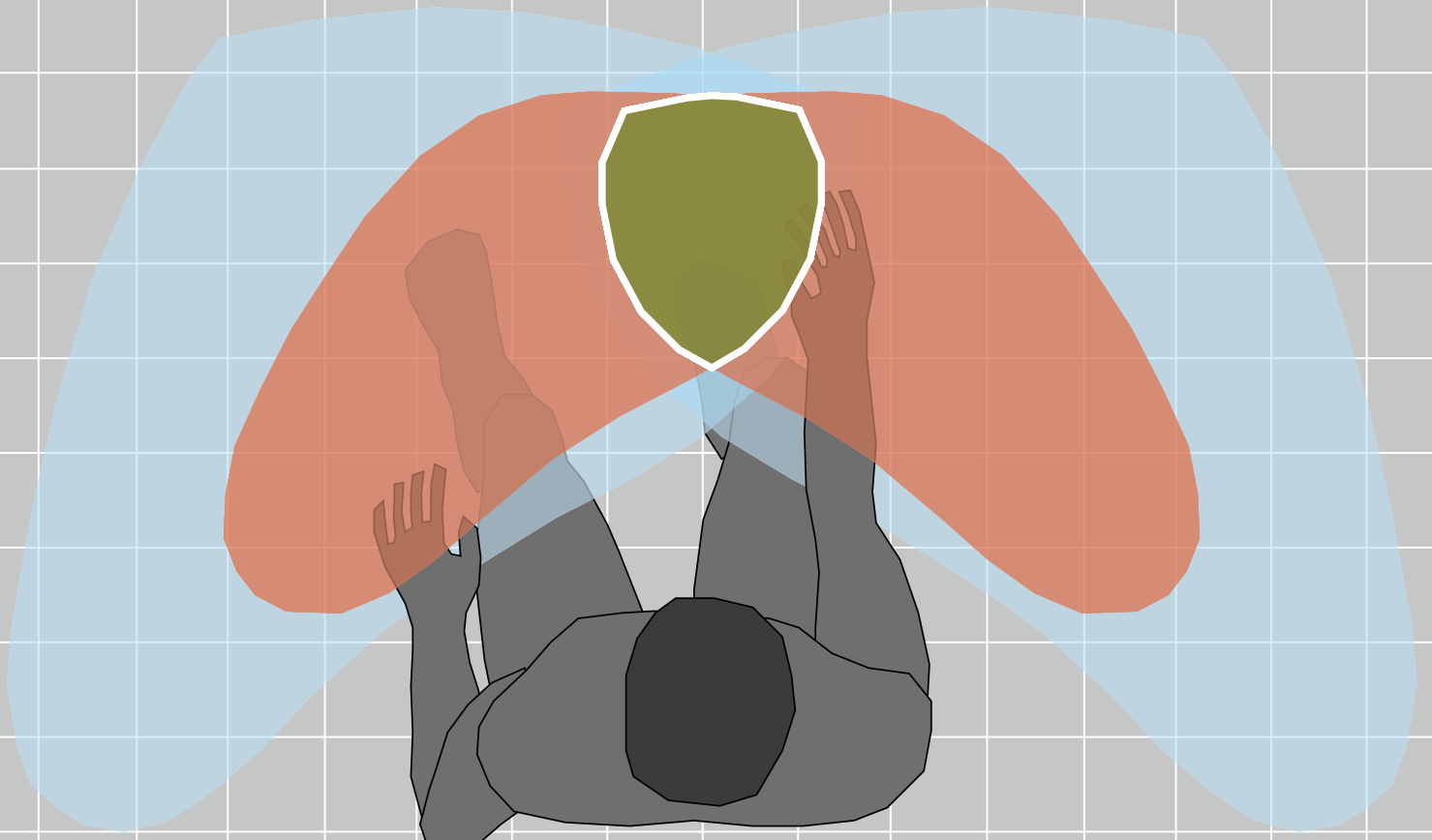

## Ergonomics – the perfect measure of things.

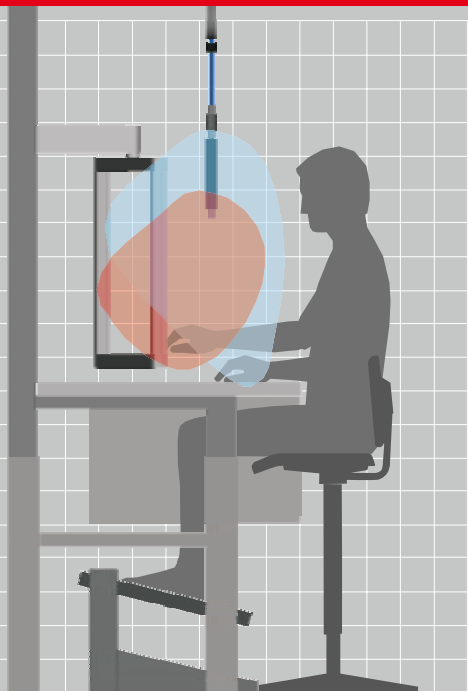

The principal aim of ergonomics is to create the ideal conditions for manual work and the use of technical systems and tools. Throughout their lives, employees will spend an average of 10,000 days at their work bench. Poor posture, movements and processes therefore have enormous consequences – for both the employee's health and business productivity.

**The fundamental rules for ergonomic work bench systems:  
The height of a work bench should be optimised to the employee's height.**

A correct seating posture means better work. Expenditure on an ergonomically optimised work bench is a sound investment in preventing work-related diseases and boosting employee performance. Changing between different working positions (standing and sitting) and postures is also good for the employee's health.

That is why every table is height adjustable, with electrical height adjustment available as an option.

**Optimised handling range.**

Any form of ergonomic work bench planning has to start with the characteristics of employees and the space within which they move (reaching distances).

As a rule, all parts, tools and accessories should be within easy reach for the employee. Making sure parts are readily to hand saves employees from having to contort themselves to reach things. As a result, employees don't need to flex or bend their wrists when handling parts, thus cutting the incidence of severe stress and injuries resulting from repetitive movements and uneven strain.

To help you create the optimum ergonomic handling range, item offers working surfaces in three widths and two depths, as well as uprights (rear wall frames) for each table that can also be fitted with overhangs (canopy frames).

## Perfect parts provision.

Short distances make processes faster. An ergonomically designed work bench also boosts the productivity of your employees. To prevent unnecessary movements, all handling ranges need to be kept as short as possible.

As a result, it is best to ensure employees can lay their hands on containers easily. They should be positioned so that employees can remove items from them in a flowing motion, their hand tracing an upward arc as it moves away from the body.

The more often a container needs to be used, the closer it should be to the employee. To prevent unnecessary stress (e.g. through lifting and lowering), heavy items should be stored in containers that are low down in the handling range.

Our standard range provides the ideal accessories for optimising your parts provision.

## Optimum lighting.

Lighting that is tailored to the work bench and the activities carried out there is key to high efficiency and processing quality. Indeed, optimum lighting prevents premature tiredness, improves concentration and reduces the risk of errors. Avoid stark contrasts, glare and reflectivity.

We have the right lights for all your needs!

Keeping everything close to hand

Reducing space requirements

Reducing material stock levels

Get the most out of employees by preventing fatigue in the workplace

Increasing productivity by creating ideal working conditions

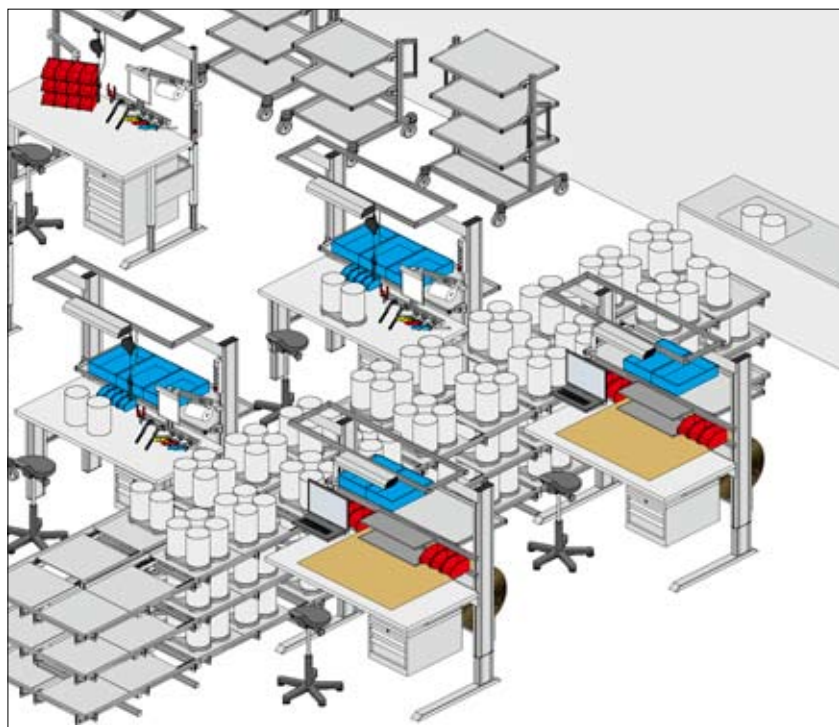
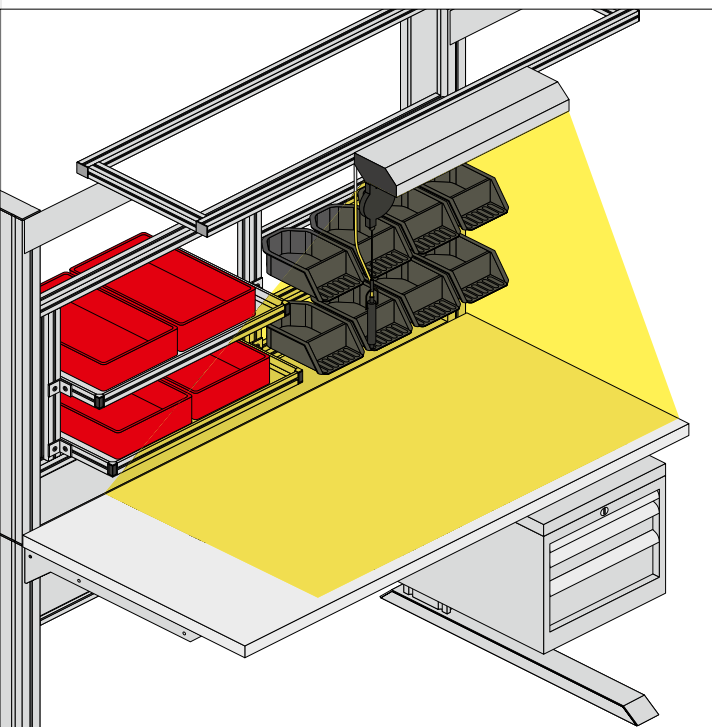



## Full protection for semiconductors.



ESD stands for ElectroStatic Discharge and describes the processes and effects involved in the equalisation of electrical charges between two unevenly charged materials. If these materials come into contact, positive and negative charges are exchanged.

Each year in industry, electrostatic discharges cause damage that runs into the millions.

As technological advances in microelectronics continue to gather pace, semiconductor components are becoming increasingly complex. As a result, measuring devices, production equipment and, of course, electronic workpiece components themselves are becoming ever more sensitive to ESD pulses.

Although humans do not have a heightened sensitivity to electrostatic build-up and discharges, it is a completely different story for electronic components. Even just a few hundred volts can cause incalculable damage to these devices, without leaving any visible traces to the casual observer.

As a result, ESD protection is a crucial requirement for any modern work bench.

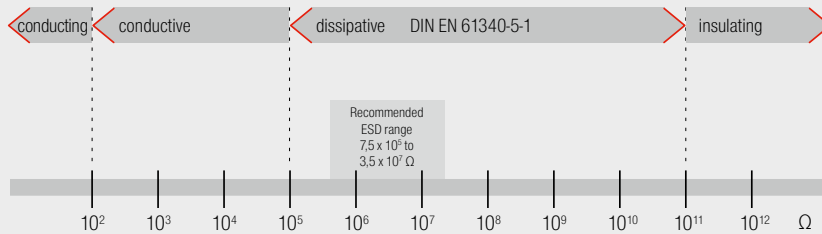



**ESD-safe equipment from item – protection you can rely on**

item offers the right ESD protection for every aspect of your working environment.

We believe that protection against electrostatic discharge begins with the work bench concept itself.

- Our range of electrostatically dissipative HPL working surfaces protects the entire table top area.
- ESD Table Mats make large areas of the working surface ESD-safe.
- ESD Wristbands help to integrate operators into the ESD circuit.



A table for every situation.

TABLE  
E

Electrical height adjustment

3 widths, 2 depths

Memory function

## Work bench E

The new item work bench E – designed specifically for your production, maintenance and customer services operations.

Easy-to-use and flexible electrical table height adjustment system with memory function allows users to adjust the working height of the work bench to their needs.

The design of the work bench, with two table columns at the rear of the table and the working surface positioned on profiled steel supports offers users extremely generous legroom. The working surface can accommodate loads of up to 2,000 N.

Work bench E is available in three widths and two depths. The working surface can be supplied in four material qualities – plastic coated, high pressure laminate (HPL), HPL/ESD-safe and beech multi-ply.

You can combine work bench E with a number of useful accessories from our broad range of add-ons. These include solutions for power and data supply, work bench lighting, pivot arms, a diverse range of ESD accessories and mounting systems for PCs and tools.

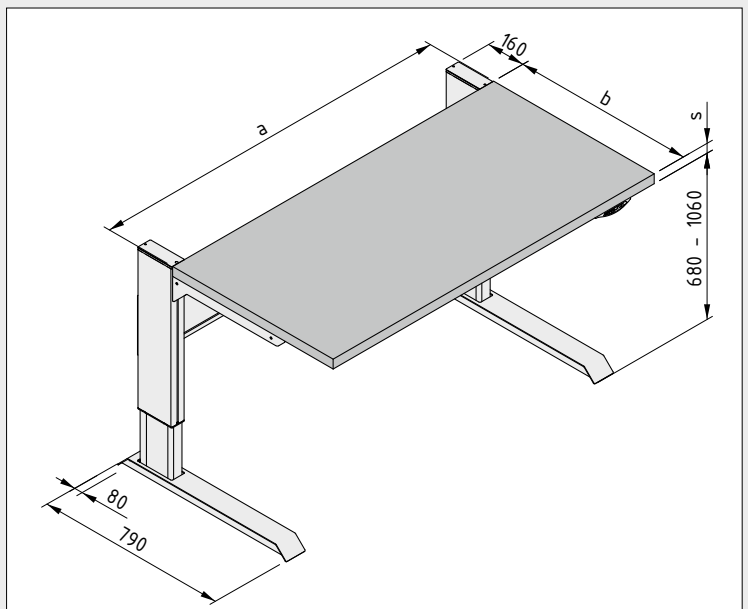

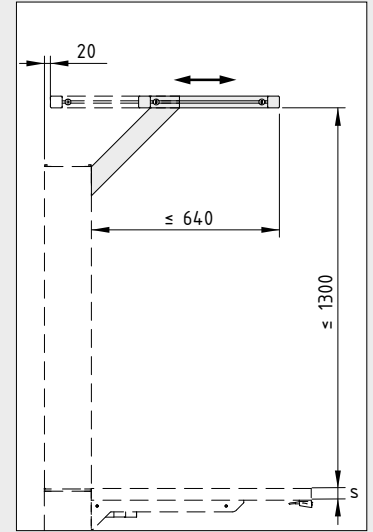
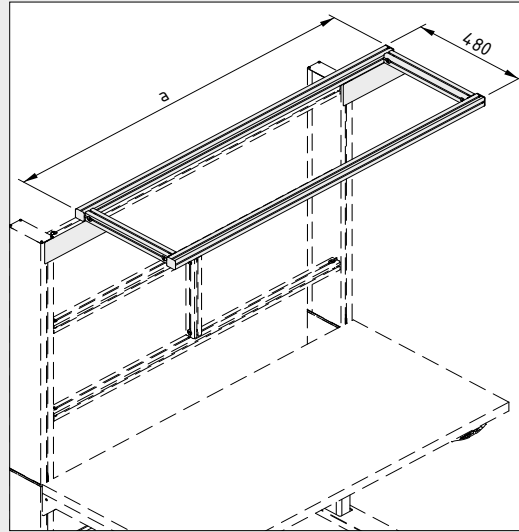
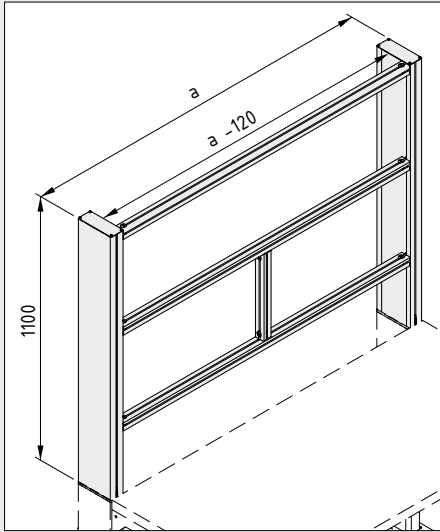

### The Upright

### The Overhang

Work bench E can be fitted with a suitable table Upright and Overhang to enable optimum positioning of materials and tools in the handling area. The height and reach of the Overhang are infinitely adjustable.

### The Cable Duct

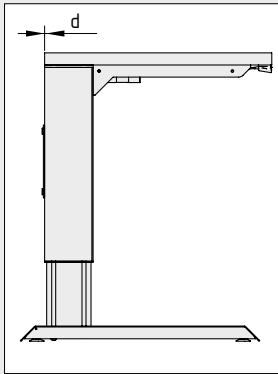

The Table Top can be fitted directly over the table columns ( $d = 0$ ) or in front of the columns ( $d = 160$  mm). The latter option means that Cable Duct E can then be fitted between the columns.



A new Cable Duct that has been specially developed for this application is available as an optional accessory for work bench E. It is fitted between the table columns.

Work Bench E Dimensions a x b mm	Table Top material				Optional attachments		
	plastic coated s = 25 mm	high pressure laminat s = 30 mm	high pressure laminat/ESD s = 30 mm	beech multi-ply s = 40 mm	Upright	Overhang (Upright required)	Cable Duct E
1200 x 600	•	•	•	•	○	○	○
1200 x 750	•	•	•	•	○	○	○
1500 x 600	•	•	•	•	○	○	○
1500 x 750	•	•	•	•	○	○	○
1800 x 600	•	•	•	•	○	○	○
1800 x 750	•	•	•	•	○	○	○

- Required
- Optional

The heavyweight.

TABLE  
4E

Electrical height adjustment

Extremely strong

Memory function



## Work bench 4 E

The new item work bench 4 E - for work benches that have to exhibit exceptional stability and load-carrying capacity.

In addition to an easy-to-use electrical height-adjustment system, one of the key advantages of the Line 4 E is its exceptional load-carrying capacity of up to 4,000 N.

The Table Top is supported by four columns. This design is specifically intended for the accommodation/setting down of heavy objects and tools.

Work bench 4 E is already available in three standard widths and two standard depths.

Work bench 4 E can be combined with any of the accessories for the new item work bench range to configure the right system for your needs.

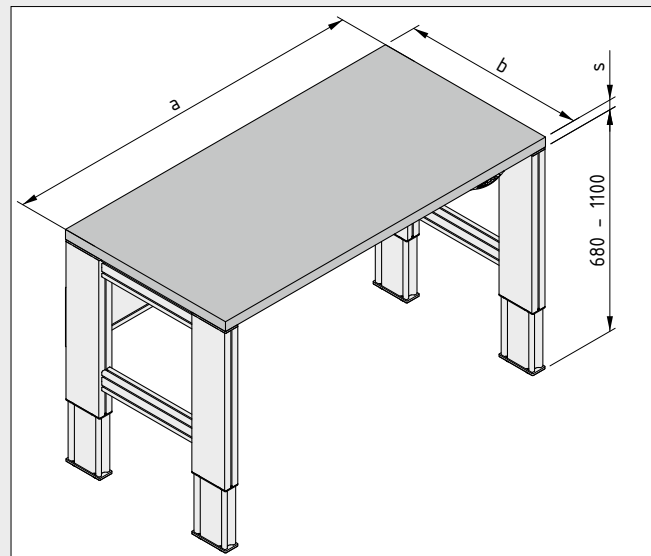

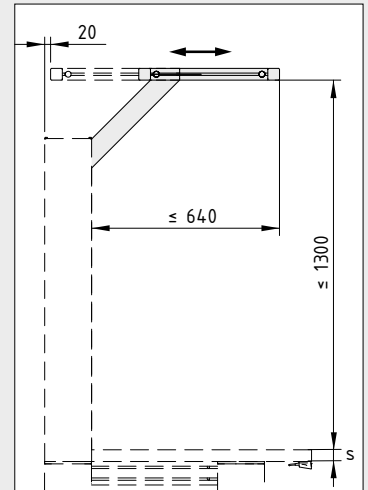
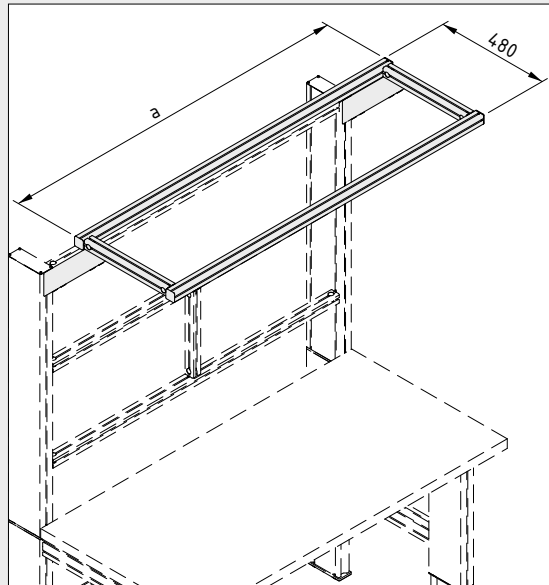
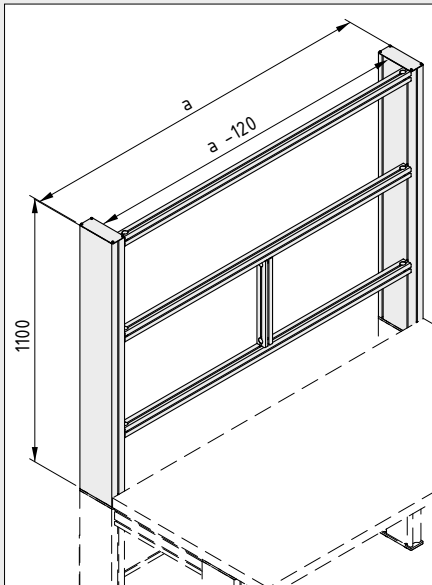

### The Upright

### The Overhang

If required, work bench 4 E can be enhanced with the addition of a suitable table Upright and Overhang and a Cable Duct.

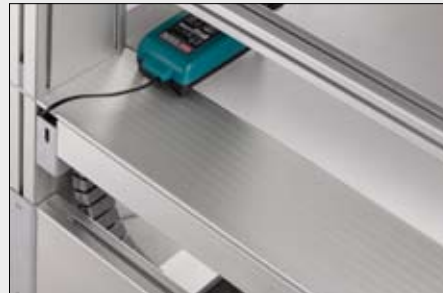

### The Cable Duct

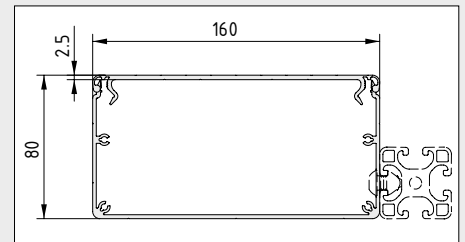

A new Cable Duct that has been specially developed for this application is available as an optional accessory for work bench E. It is fitted between the lifting columns.

Work Bench 4 E Dimensions a x b mm	Table Top material				Optional attachments		
	plastic coated s = 25 mm	high pressure laminated s = 30 mm	high pressure laminated/ESD s = 30 mm	beech multi-ply s = 40 mm	Upright	Overhang (Upright required)	Cable Duct E (Upright required)
1200 x 600	•	•	•	•	•	○	○
1200 x 750	•	•	•	•	○	○	○
1500 x 600	•	•	•	•	•	○	○
1500 x 750	•	•	•	•	○	○	○
1800 x 600	•	•	•	•	•	○	○
1800 x 750	•	•	•	•	○	○	○

- Required
- Optional



F for flexibility.

TABLE  
F

Infinite, manual height adjustment

3 widths, 2 depths

### Work bench F

The new item work bench F – simple, flexible, cost-effective and ergonomic.

Our F model work benches incorporate infinite, manual height adjustment, enabling their flexible deployment as work benches for seated or standing work. Accommodate up to 4,000 N.

They are also ideal for integration into production lines as part of a material flow system.

Select from three possible widths, two depths and four different working surfaces – including an ESD-safe option – to create your own customised work bench from our standard portfolio.

The F Line is rounded off by a host of new, innovative solutions for providing power, data and light at the work bench, Pivot Arms for the ergonomic handling of small parts, a broad range of ESD-safe equipment and various mounting systems for PCs and tool handling.

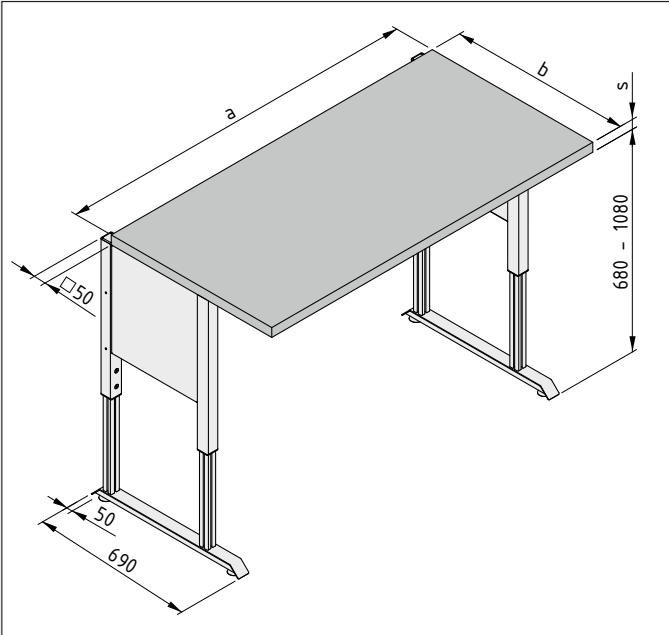

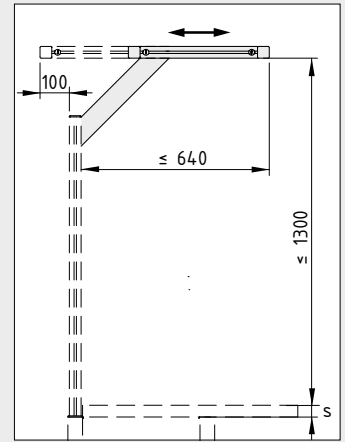
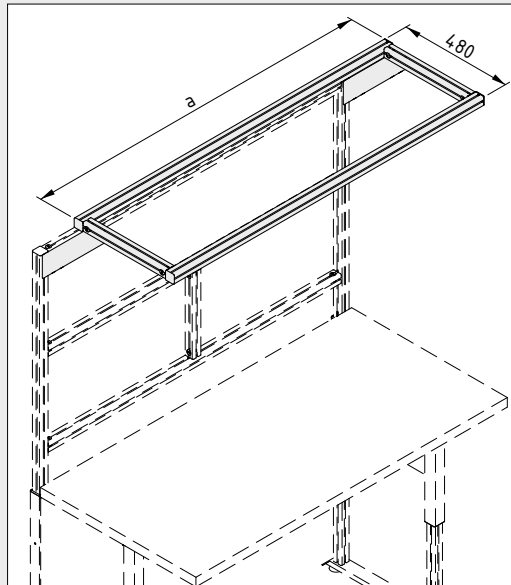
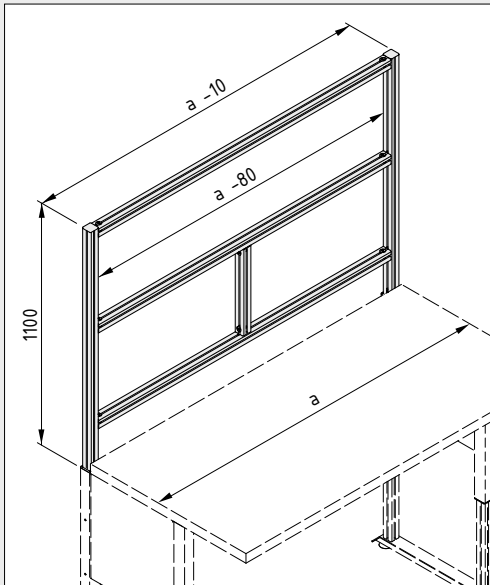

### The Upright

### The Overhang

The work bench can be fitted with a suitable table Upright and Overhang to enable optimum positioning of materials and tools in the handling area. The height and reach of the Overhang are infinitely adjustable.

If required, work benches F can be fitted with a modular Cable Duct 160 KW (see page 30 on power and data supply). Your item partner will be on hand to offer advice and put together a package to meet your specific needs.

Work Bench F Dimensions a x b mm	Table Top material				Optional attachments	
	plastic coated s = 25 mm	high pressure laminated s = 30 mm	high pressure laminated/ESD s = 30 mm	beech multi-ply s = 40 mm	Upright	Overhang (Upright required)
1200 x 600	•	•	•	•	○	○
1200 x 750	•	•	•	•	○	○
1500 x 600	•	•	•	•	○	○
1500 x 750	•	•	•	•	○	○
1800 x 600	•	•	•	•	○	○
1800 x 750	•	•	•	•	○	○

- Required
- Optional



Now you can plan your work bench online, too.

[workbench.item24.com](http://workbench.item24.com)



Three-point flexibility.

TABLE TRIGO F

## Work bench TRIGO F

The new item work bench TRIGO F – the special table design that brings ergonomic benefits.

The Tables in the TRIGO F Line support infinite, manual height adjustment and, thanks to their triangular shape, are suitable for use as production island modules or for corner applications (e.g. changes of direction in interlinked work benches).

TRIGO F is also ideal for integration into your production lines in terms of ergonomics. It must always be connected to a second Table.

Tables in this Line are available in two depths and with four different working surfaces, including an ESD-safe variant.

The TRIGO F Line is rounded off by a host of new, innovative solutions for providing power, data and light at the work bench, Pivot Arms for the ergonomic handling of small parts, a broad range of ESD-safe equipment and mounting systems for PCs and tool handling.

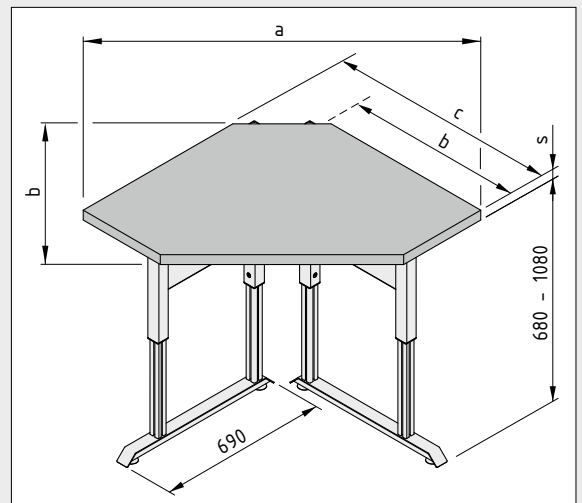

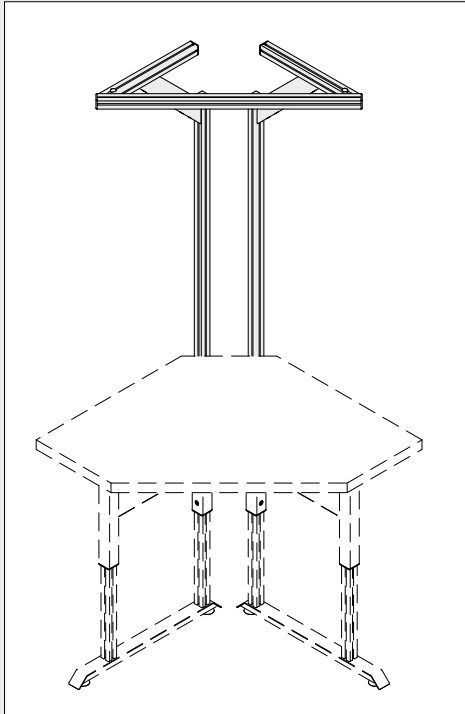

### The Upright

Work bench TRIGO F can be fitted with a suitable table Upright and Overhang to enable optimum positioning of materials and tools in the handling area.

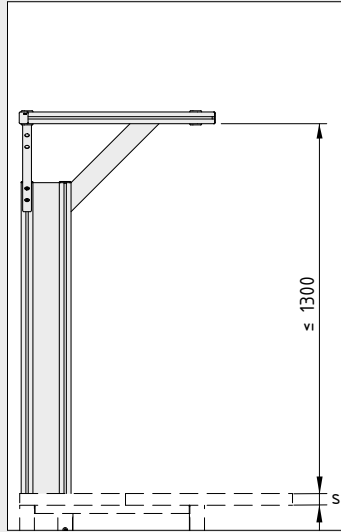

The height of the Overhang for TRIGO F is infinitely adjustable.

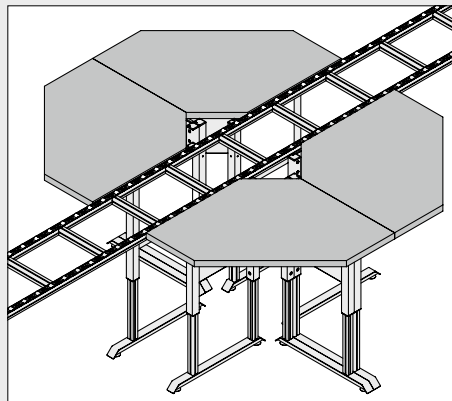
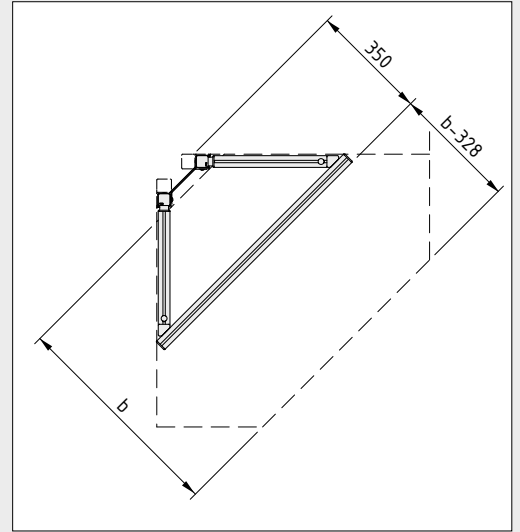

Multiple work bench TRIGO F units combined into a production island.

Work Bench TRIGO F Standard sizes available a x b x c mm	Table Top material				Optional attachments Upright + Overhang
	plastic coated s = 25 mm	high pressure laminated s = 30 mm	high pressure laminated/ESD s = 30 mm	beech multi-ply s = 40 mm	
1100 x 600 x 780	•	•	•	•	○
1315 x 750 x 930	•	•	•	•	○

- Required
- Optional



Now you can plan your work bench online, too.

[workbench.item24.com](http://workbench.item24.com)



All bases covered.

1

## Table Tops to suit every need

Four different working surfaces for the new item work bench range – the ideal surfaces for the broadest range of applications. You can combine our new work benches E, 4 E, F and TRIGO F with the working surface that best suits your requirements. There are six different sizes available for the E, 4 E and F models. Due to its triangular shape, there are two different sizes available for TRIGO F.

Each size of working surface can be supplied in a choice of four materials/thicknesses – plastic coated (25 mm), high pressure laminate (HPL, 30 mm), HPL/ESD-safe (30 mm) and beech multi-ply (40 mm).



2 different shapes

4 different materials

6 different sizes



1) Beech multi-ply, 40 mm thick  
Moisture-resistant adhesive  
Grain in longitudinal direction, edges chamfered  
All-over UV lacquer

2) High-pressure chipboard laminate (HPL), 30 mm thick  
High impact resistance  
Colour similar to RAL 7035  
Edges sealed all around with edge strip (ABS)

3) As for variant 2 but with additional ESD-volume conductivity  
Volume resistance  $1 \times 10^4 - 1 \times 10^9 \Omega$

4) Chipboard, plastic coated, 25 mm thick  
Colour similar to RAL 7035  
Edges sealed all around with edge strip (ABS)



Smooth transitions.



### Work bench accessories

Two adapter sets allow Drawer Units to be fitted to all E, 4 E and F tables. The depth of your table determines which adapter set you need.

A crucial component for any ergonomic work bench – the electrostatically dissipative foot rest can be positioned at will and can be easily adjusted to the preferred height thanks to its gas spring.

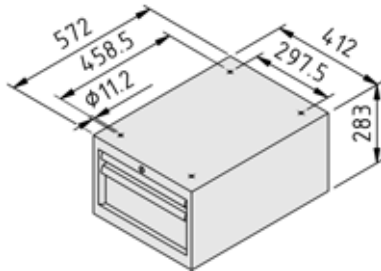

**Drawer Unit S2 H283**

Steel sheet  
 1 drawer 50 mm high  
 1 drawer 150 mm high with divider  
 Labelling cards for grip rails  
 Cylinder Lock with 2 keys  
 m = 31.0 kg

grey, similar to RAL 7042, 1 pce.

0.0.603.18

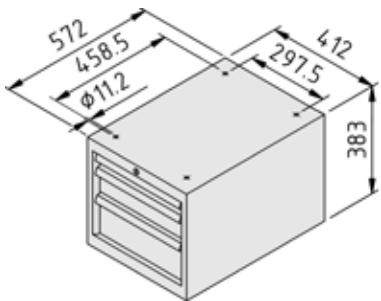

**Drawer Unit S3 H383**

Steel sheet  
 1 drawer 50 mm high  
 1 drawer 100 mm high with divider  
 1 drawer 150 mm high  
 Labelling cards for grip rails  
 Cylinder Lock with 2 keys  
 m = 40.6 kg

grey, similar to RAL 7042, 1 pce.

0.0.603.19

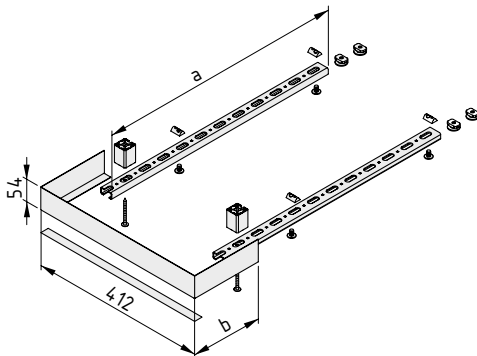

**Drawer Unit Adapter Set, table depth 600**

2 C-Profiles, St, bright zinc-plated  
 Facing, St, grey similar to RAL 7042  
 2 spacers, Al, natural  
 Double-sided adhesive tape  
 Screws and fastening elements  
 Notes on Use and Installation  
 a = 578 mm    b = 153 mm    m = 1.7 kg

1 set

0.0.636.55

**Drawer Unit Adapter Set, table depth 750**

2 C-Profiles, St, bright zinc-plated  
 Facing, St, grey similar to RAL 7042  
 2 spacers, Al, natural  
 Double-sided adhesive tape  
 Screws and fastening elements  
 Notes on Use and Installation  
 a = 726 mm    b = 303 mm    m = 2.2 kg

1 set

0.0.636.56

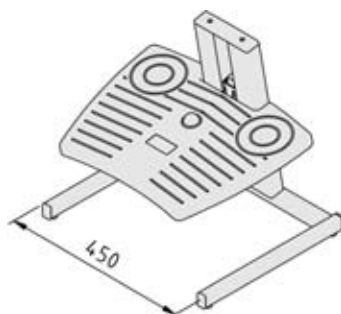

**Foot Rest 450x400 ESD**



Base frame, St  
 Lifting Column, Al  
 Tread plate, PA  
 Notes on Use and Installation

black, 1 set

0.0.600.72



## Well connected.

For us, ergonomics and health and safety start right from the power supply.

Virtually every work bench needs power in one form or another. That's why integrating a power supply is a key aspect of work bench planning.

Whether electricity, compressed air or data – you can stay flexible by integrating Distribution Strips, Multi-Socket Power Strips and compressed air supplies into your working environment. Depending on requirements, the power supply can be fed in above or below working level. Making subsequent changes to the work bench design is also extremely straightforward.

The problem of long cables and hoses getting in the way can also be consigned to the past.

### 24

#### Distribution Strip

Four power sockets, three empty slots for inserts including RJ45 and USB jacks and an ON/OFF switch with indicator light – all in one unit. Several Distribution Strips can also be connected in series (Adapter 0.0.417.45 is needed to do this). The RCD Unit provides the work bench with protection against excessive residual currents.



 **26** Multi-Socket Power Strip, 8 outlet, 19"  
Multi-Socket Power Strip with eight sockets (German domestic standard) and an ON/OFF switch with indicator light in a robust plastic housing, including power cord.

 **28** Compressed Air Manifold  
Robust unit with three compressed air connections via vent couplings G 3/8 (nominal diameter 7.2 mm). Can be connected directly to the work bench wherever needed.

 **29** Flexible Conduit  
The Flexible Conduit guides cables to the work bench Cable Duct. Includes floor securing

 **30** Related products from our full range

Powerful multi-tasking.



## Distribution Strip

A powerful multi-tasker with a whole range of connection options – the item Distribution Strip. The Distribution Strip comprises 4 power sockets (German domestic standard), 3 empty slots for inserts that allow the connection of network and telephone lines (RJ45) or USB cables and an all-pole ON/OFF switch with indicator light. It is easily screwed to the profile of a work bench, an upright or an overhang using an Angle Fastening Set.

The Distribution Strip is connected to the power supply with a 3-meter power cord (accessory 0.0.417.42) via the system plug, which can also be used to make a connection with Multi-Socket Power Strips, Light Fittings 55W and Lamps 35W. Adapters can also be used to connect several Distribution Strips in series. If residual current exceeds acceptable parameters or an overload occurs, the separate RCD Unit for the Distribution Strip creates an all-pole break between the Distribution Strip and the power supply.

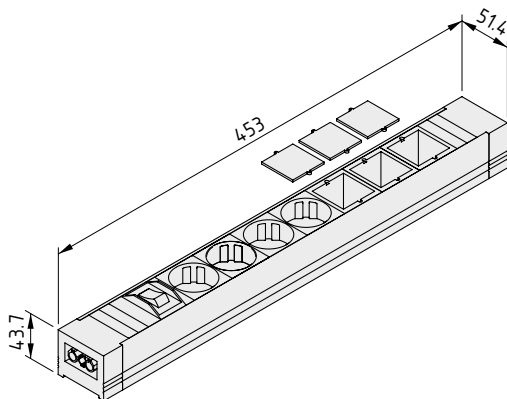
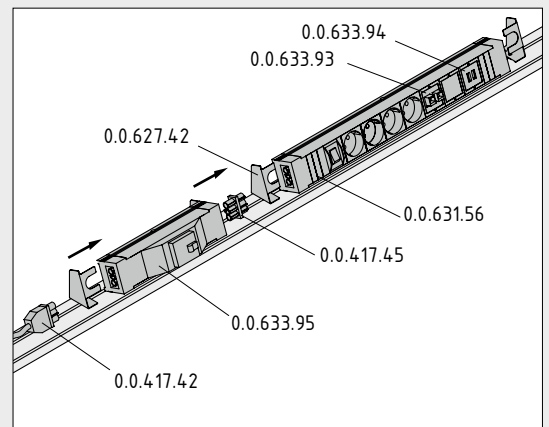

### Distribution Strip

4 power sockets (German domestic standard) with all-pole ON/OFF switch  
3 empty slots for inserts  
System plug connection  
m = 530.0 g

1 pce.

0.0.631.56

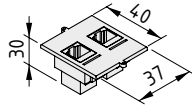

**Distribution Strip Insert RJ45**

Distribution strip module  
2 RJ45 jacks  
m = 35.0 g

1 pce. 0.0.633.93

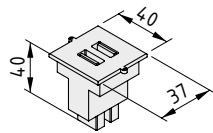

**Distribution Strip Insert USB**

Distribution strip module  
2 USB ports  
m = 35.0 g

1 pce. 0.0.633.94

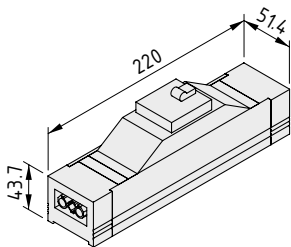

**Distribution Strip RCD Unit**

System plug connection  
Rated tripping current: 30 mA  
Overload protection: 25 A  
m = 435.0 g

1 pce. 0.0.633.95

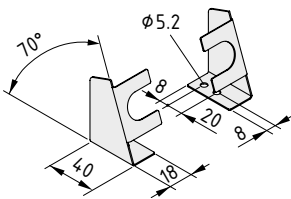

**Multi-Socket Power Strip Angle Fastening Set 70°**

2 angle brackets 70°, St, bright zinc-plated  
m = 65.0 g

1 set 0.0.627.42



**Connecting Cable, Socket / Earthed Plug**

Cable length 3 m (1.5 mm<sup>2</sup>)  
m = 370.0 g

black, 1 pce. 0.0.417.42



**Adapter, Socket / Plug**

incl. dowel  
m = 13.0 g

black, 1 set 0.0.417.45



Your closest power supply.

### Multi-Socket Power Strips, 8 outlet, 19", with conventional power cord

The item Multi-Socket Power Strip, 8 outlet – the ideal addition to your work bench power supply. Eight power sockets (German domestic standard) and an all-pole ON/OFF switch with indicator light – all in a plastic housing with fittings to accommodate Rebate Profile 19". The 8-outlet Multi-Socket Power Strip can also be placed in Cable Duct E of the work bench.

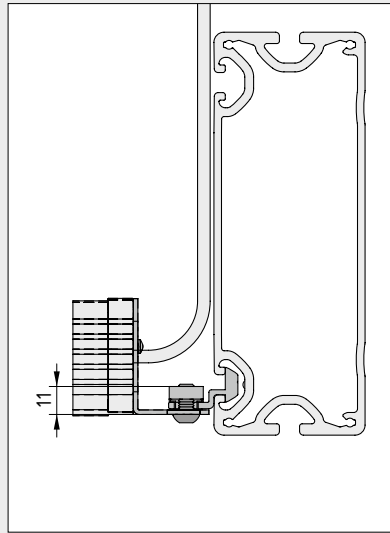
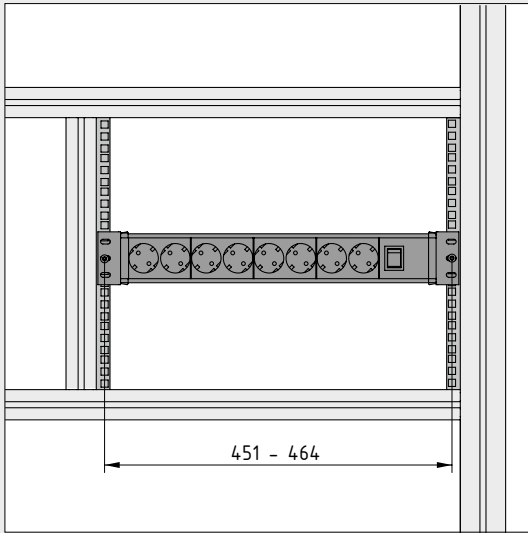

Because this robust, industrial quality Multi-Socket Power Strip can be fitted to the profile grooves of a work bench, upright or overhang, positioning your power supply precisely where it is needed couldn't be simpler. Mains connection via a fixed conventional power cord that is included in the scope of supply.

Multi-Socket Power Strip 19'' is fitted to a Profile 8 groove using Rebate Profile 19''.

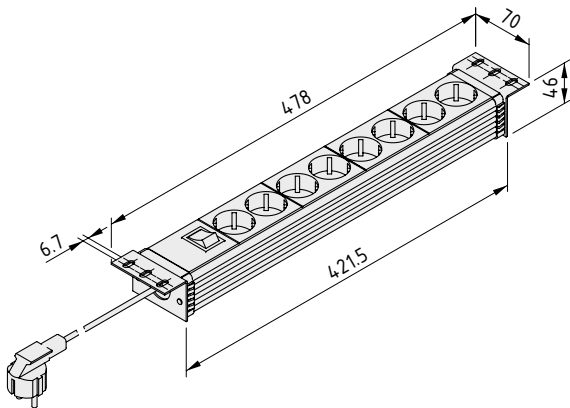

**Multi-Socket Power Strip, 8 outlet, 19'', with conventional power cord**

8 power sockets (German domestic standard)  
 Feed cable 1.5 mm<sup>2</sup>, max. 16 A, l = 3 m  
 ON/OFF switch, lit  
 m = 870.0 g

1 pce.

0.0.631.79

A breath of fresh air.



## Compressed Air Manifold

Compressed air connections precisely where you need them – with the Compressed Air Manifold from item. Fit the Compressed Air Manifold to work bench profiles and use the three vent couplings as quick-connect couplings for your compressed air devices (operating pressure  $P_{perm} = 8$  bar). Nominal diameter of couplings: 7.2 mm, thread G 3/8. Connection for the compressed air feed line: G 1/2.

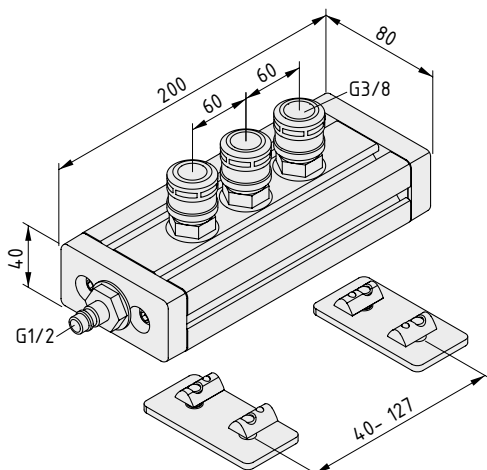

### Compressed Air Manifold

Compressed Air Manifold, Al, natural  
3 vent couplings G 3/8, St - ND 7.2 mm  
Male connector G 1/2  
2 Flat Brackets 8 40, St, black  
4 Fastening Sets, St, bright zinc-plated  
m = 1.8 kg

1 set

0.0.635.98

A guiding role.



## Flexible Conduit E

The new item Flexible Conduit E is a flexible and neat solution for guiding cables from the floor to the table. It feeds cables into the work bench Cable Duct and eliminates the workplace hazards posed by loose cabling. Length 1.1 metres, including base plate.

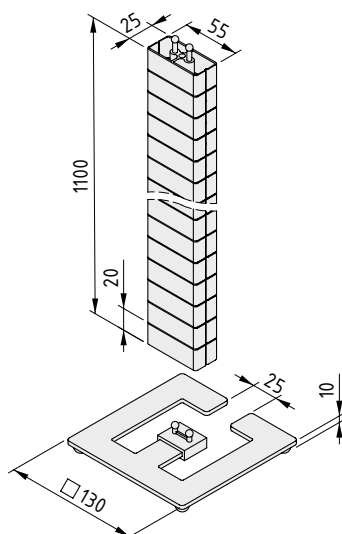

### Flexible Conduit E

Flexible Conduit 55x25, PP, white aluminium, similar to RAL 9006

Base plate, St, white aluminium, similar to RAL 9006

m = 605.0 g

1 pce.

0.0.635.78

## Related products from our full range.



<b>Multi-Socket Power Strip, 5 outlet, with system plug</b>	
1 set	0.0.627.44
<b>Multi-Socket Power Strip, 5 outlet, with conventional power cord</b>	
1 set	0.0.627.43



Modular Cable Duct for all types of table designs. The system elements are designed to create large cross-section Cable Ducts that are able to hold both Multi-Socket Power Strips and power packs. Lines can be run in and out of the Cable Duct at any position. Cables can be installed or exchanged quickly by opening the swing-up cover. A flexible brush provides a seal between the cover and the Cable Duct and also prevents cables slipping out (see Comprehensive Catalogue for MB Building Kit System, Special Elements section).

<b>Support Profile KW</b>	
natural, cut-off max. 3000 mm	0.0.474.75
<b>Wall Profile KW</b>	
natural, cut-off max. 3000 mm	0.0.474.79
<b>Wall Profile 160-45° KW</b>	
natural, cut-off max. 3000 mm	0.0.474.76
<b>Lid Profile 160 KW</b>	
natural, cut-off max. 3000 mm	0.0.474.78
<b>Sealing Brush KW</b>	
black, 1 pce., length 2000 mm	0.0.488.47
<b>Catch 160 KW</b>	
black, 1 pce.	0.0.474.70
<b>Conduit Cap 160-45° KW</b>	
1 set	0.0.474.98



Detailed descriptions of these products can be found online.

[www.item24.com](http://www.item24.com)



## Focused lighting.

Casting the right light on any work bench – with the LED Illuminated Magnifier and the LED Machine Light Fitting. Whether you need the pin-point lighting of an illuminated magnifier at your work bench, or want to light up the entire working area evenly, we have the perfect lighting solution for you!

-  **32** LED Illuminated Magnifier  
Award-winning work bench light and magnifier in one, extremely economical with power consumption of only approx. 6 W
-  **33** LED Machine Light Fitting  
Machine Light Fitting in sealed aluminium housing, power consumption of approx. 7 W
-  **34** Related products from our full range

The focused lighting solution.

Dimmable

Practical sensor switch



## LED Illuminated Magnifier

Precise lighting – the item LED Illuminated Magnifier. This beautiful and functional winner of the redden design award 2009 is a work bench light and magnifier in one. With a lens that provides 2.3 times magnification, it is the perfect lighting solution for the precise inspection and handling of workpieces. The magnifier's output is approx. 6 W at a rated voltage of 100-240 V AC. It is switched on and off using a convenient sensor switch and can also be dimmed. A table clamp suitable for all item working surfaces is included in the scope of supply.

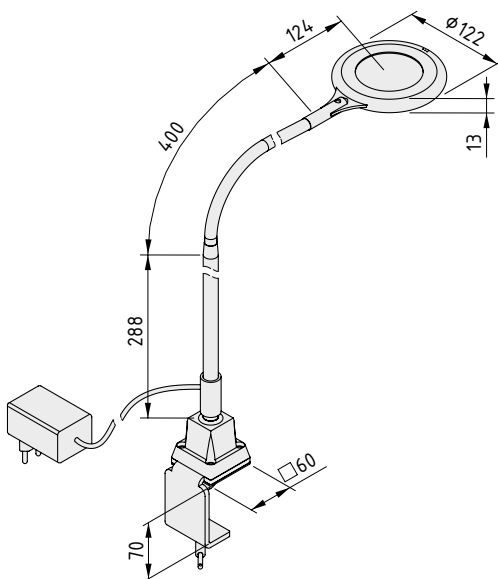

### LED Illuminated Magnifier

Table clamp 0-65 mm  
Flexible tube, 400 mm  
Sensor switch with dimmer  
Rated voltage: 100-240 V AC  
Protection class II  
Power cord, black, L = 2.3 m  
with plug transformer  
Lens diameter 72 mm, 5.3 dioptr  
m = 1.5 kg

1 pce.

0.0.631.71

A guiding light.

## LED Machine Light Fitting

The item LED Machine Light Fitting – putting your processes in the right light. Practical, dust- and water-tight Machine Light Fitting in aluminium housing with 5 W output for blanket illumination of the workpiece or direct lighting of a specific area. Operating voltage is 24 V DC, protection IP67.

The LED Machine Light Fitting is switched on and off via external switches on the power supply.

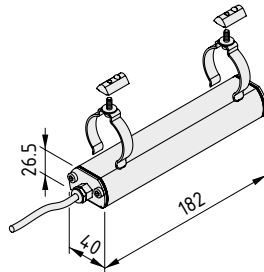

### LED Machine Light Fitting

Aluminium housing IP67  
 2 fastening clamps with screws and T-Slot Nuts 8 St  
 Fastening elements  
 Rated voltage: 24 V DC  
 Protection class III  
 Output: 5 W  
 Power cable, black, L = 3 m  
 m = 0.4 kg

1 pce.

0.0.631.73

## Related products from our full range.



Sturdy Light Fitting for illumination of workplaces and machines. The integrated swivel profile with Line 8 system groove supports 7 setting angles.

### Light Fitting 55W, 230V

1 pce.

0.0.417.34



### Connecting Cable, Socket / Earthed Plug

black, 1 pce.

0.0.417.42



Dust-tight and water-tight industrial spotlight (IP 67) in a low-voltage (12 V) design. The aluminium housing for the Light Fitting is equipped for fastening with Profile 8 grooves. The voltage supply to the electronic transformer is provided via the Connecting Cable, Socket / Earthed Plug (0.0.417.42) to a 230 V safety contact socket.

### Lamp 35W

1 set

0.0.417.60

### Lamp 35W with Flexible Tube

1 set

0.0.417.71

### Electronic Transformer 105W

1 pce.

0.0.417.75



Detailed descriptions of these products can be found online.

[www.item24.com](http://www.item24.com)



## Perfect placement.

Maximise your flexibility by keeping everything you need close to hand.

Pivot Arms are an ergonomic means of keeping small parts, holders and tools within easy reach at all times. item offers you three different variants.

- 📄
**36**
**Pivot Arm 8 370 light**  
 Single Pivot Arm, 370 mm reach, max. load-carrying capacity 120 N.
- 📄
**36**
**Double Pivot Arm 8 695**  
 Articulated Pivot Arm with extended reach (695 mm), max. load-carrying capacity 80 N.
- 📄
**38**
**Double Pivot Arm 8 695 heavy-duty**  
 Articulated Pivot Arm with high load-carrying capacity, 695 mm reach, max. load-carrying capacity 140 N.
- 📄
**39**
**Related products from our full range**



More pivots for added flexibility.



### Pivot Arm 8 370, light

Our lightweight option for improved ergonomics – the item Pivot Arm 8 370. This stable Pivot Arm can be fitted to an Upright on any of the new item work benches easily. The braking torque can be individually adjusted at each joint, enabling you to tailor the manoeuvrability of the Pivot Arm to your needs. The end swivel joint can be rotated 360°. The Pivot Arm can reach approximately 370 mm. It can accommodate a maximum (vertical) load of 120 N.

### Double Pivot Arm 8 695

The Double Pivot Arm 8 695 from item – for double the reach and maximum flexibility! Both arms are connected via a joint in order to increase the pivot radius. The heavy-duty connecting joint can be used with Profile 8 grooves. The Double Pivot Arm should only be fitted to vertical profile grooves. The Double Pivot Arm can reach approximately 695 mm and the maximum vertical load is 80 N.

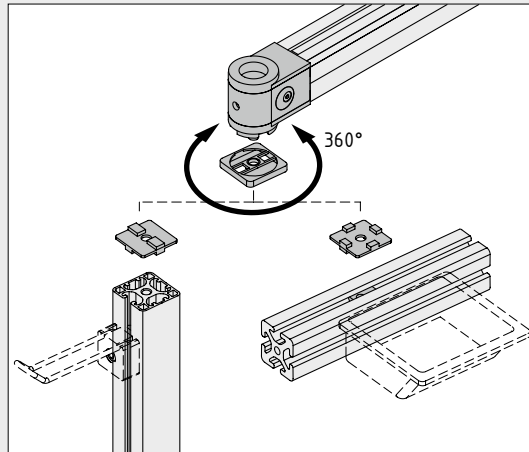

The connection can be made with either a horizontal or vertical profile groove. An end-face connection with Profiles is also possible. All the joints can be rotated through 360° and their frictional moment can be adjusted.

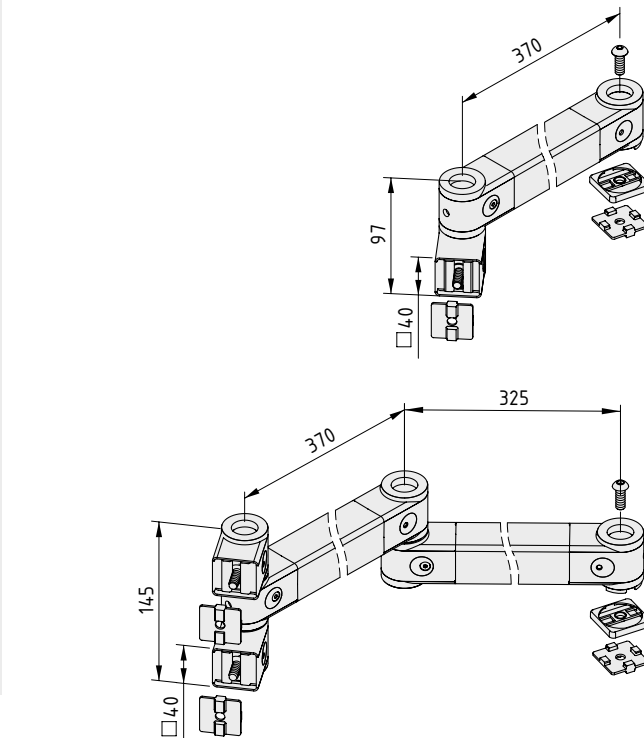

**Pivot Arm 8 370 light**



- Profiles 8 40x40 3N light
- Mounting joint
- End swivel joint
- Connecting cover, PA, grey
- 2 Connecting Plates, Al, natural
- Button-Head Screw M8x22, St, bright zinc-plated
- Notes on Use and Installation
- m = 1.4 kg

1 pce.

0.0.631.17

**Double Pivot Arm 8 695**



- Profiles 8 40x40 3N light
- 2 mounting joints
- Mid swivel joint
- End swivel joint
- Connecting cover, PA, grey
- 3 Connecting Plates, Al, natural
- Button-Head Screw M8x22, St, bright zinc-plated
- Notes on Use and Installation
- m = 2.7 kg

1 pce.

0.0.631.19

The heavy weight.



## Double Pivot Arm 8 695 heavy-duty

Double Pivot Arm 8 695 heavy-duty – move even heavy loads safely!

The heavy-duty Double Pivot Arm is connected to a simple Pivot Arm via a double mid swivel joint. The heavy-duty mounting joint can be connected to any Profiles 8. The heavy-duty Double Pivot Arm should only be fitted to vertical profile grooves.

The Pivot Arm can reach approximately 695 mm. It can accommodate a maximum (vertical) load of 140 N.

The end swivel joint can be rotated through 360° for maximum versatility.

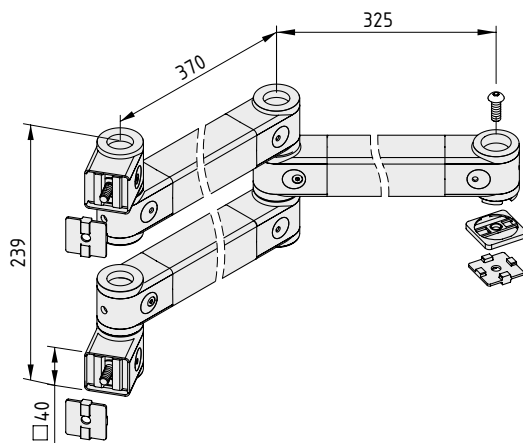

### Double Pivot Arm 8 695 heavy-duty



Profiles 8 40x40 3N light  
 2 mounting joints  
 Double mid swivel joint  
 End swivel joint  
 Connecting cover, PA, grey  
 3 Connecting Plates, Al, natural  
 Button-Head Screw M8x22, St, bright zinc-plated  
 Notes on Use and Installation  
 m = 3.7 kg

1 pce.

0.0.631.20

## Related products from our full range.



Stackable Parts Containers in various widths and heights for holding small parts within easy reach at work benches.

The Parts Containers are divided into two sections:

- Storage containers at the rear
- Front section picking tray, where a small number of components can be transferred from the main container for greater ease of handling.

### Parts Container 80x40

black, 1 pce. 0.0.432.73

### Parts Container 120x40

black, 1 pce. 0.0.432.74

### Parts Container 160x80

black, 1 pce. 0.0.432.75

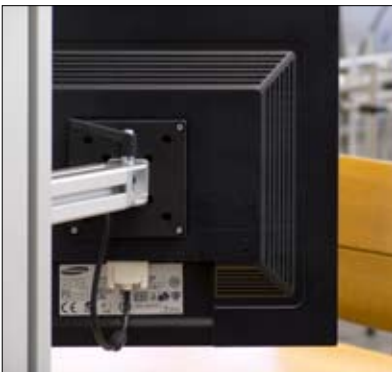

The Monitor Adapter enables flat screens to be installed (with standard fastening VESA 75 or 100) on work bench systems or production control stations.

### Monitor Adapter 8 VESA 75-100 PA

1 set 0.0.615.48



Frame Profile 8 40x20 provides a stable means of holding and securing a plastic or metal panel element (up to 4 mm thick). The corner fasteners connect seamlessly with the frame profiles and enable panels to be inserted easily across both without the need for processing. After the frame has been closed, the panel is secured with a flexible Retaining Cord to prevent movement.

### Frame Profile 8 40x20

natural, cut-off max. 6000 mm 0.0.616.95

### Corner-Fastening Set Frame 8 40x20

1 set 0.0.618.61

### Retaining Cord D6

grey, cut-off max. 20 m 0.0.622.12







Detailed descriptions of these products can be found online.

[www.item24.com](http://www.item24.com)



## Getting a grip.

New, innovative accessories for the work bench – the item range of holders. Whether hooks, holders, tool holders, magnetic holders or mounts for your PC – we have thought of everything! Choose the right solution for your work bench from a wide range of mounting accessories. The universal fastening system is suitable for all Line 8 profiles.

-  **42** **Hook 8**  
Three different hook variants in 12 mm and 24 mm widths
-  **44** **Holder 8**  
Two holders for rounded or angled objects
-  **45** **Cloth Holder 8**  
The quick-access holder for cloths
-  **46** **Bottle Holder 8**  
Holder for bottles or cans up to 100 mm in diameter



- 46** Cup Holder 8  
 Holder for mugs and cups
- 47** Tool Holder D120  
 Holds even large hand tools safely
- 48** Magnetic Holder 8  
 Magnetic Holder that fits into a profile groove and secures hand tools made from steel
- 49** Tool Balancer  
 Tool Balancers up to 1 kg and 2 kg counter-weight  
 Adjustable length, with integrated securing loop
- 50** PC Mount and Keyboard Shelf  
 Perfect support for your PC and keyboard below the working surface. PC Mount can be folded and pulled out and is height adjustable. Keyboard Shelf fitted with telescopic rails.
- 52** Related products from our full range



Stainless support.



## Hook 8

The new item Hook system - one of these three hooks will always fit your needs!  
All the Hooks are formed from stainless steel wire and can be used individually or together.

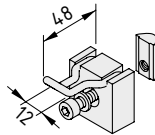
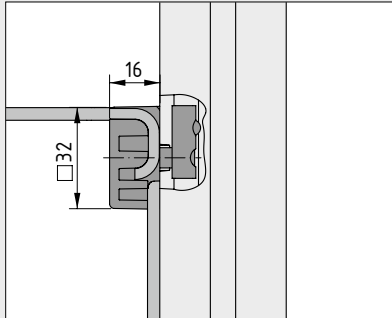

**Hook 8 40x20**



Wire, St, stainless  
 Wire mount, PA-GF, black  
 Hexagon Socket Head Cap Screw DIN 912-M6x20  
 Washer DIN 433-6.4  
 T-Slot Nut V 8 St M6  
 m = 48.0 g

1 set

0.0.624.30

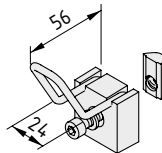

**Hook 8 40x40**



Wire, St, stainless  
 Wire mount, PA-GF, black  
 Hexagon Socket Head Cap Screw DIN 912-M6x20  
 Washer DIN 433-6.4  
 T-Slot Nut V 8 St M6  
 m = 54.0 g

1 set

0.0.624.28

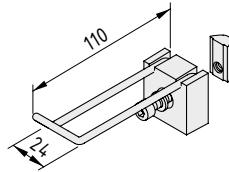

**Hook 8 80x20**



Wire, St, stainless  
 Wire mount, PA-GF, black  
 Hexagon Socket Head Cap Screw DIN 912-M6x20  
 Washer DIN 433-6.4  
 T-Slot Nut V 8 St M6  
 m = 61.0 g

1 set

0.0.624.29



Versatile support.



## Holder 8 240x80 Holder 8 D80

Holders for round and angular objects – two Holders with a whole range of uses.  
The Holder itself is formed from stainless steel wire

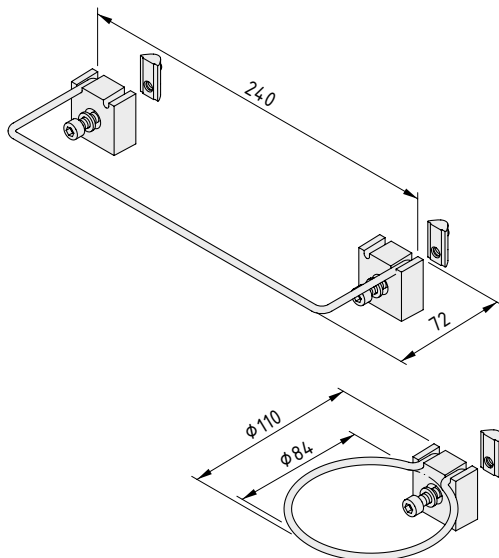

### Holder 8 240x80



Wire, St, stainless  
Wire mount, PA-GF, black  
Hexagon Socket Head Cap Screw DIN 912-M6x20  
Washer DIN 433-6.4  
T-Slot Nut V 8 St M6  
m = 74.0 g

1 set

0.0.624.31

### Holder 8 D80



Wire, St, stainless  
Wire mount, PA-GF, black  
Hexagon Socket Head Cap Screw DIN 912-M6x20  
Washer DIN 433-6.4  
T-Slot Nut V 8 St M6  
m = 53.0 g

1 set

0.0.624.32

Safely tucked up.



## Cloth Holder 8

A place for everything and everything in its place – the item Cloth Holder helps turn this into a reality for your work bench.

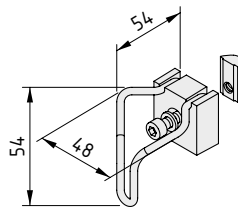

### Cloth Holder 8

Wire, St, stainless  
 Wire mount, PA-GF, black  
 Hexagon Socket Head Cap Screw DIN 912-M6x20  
 Washer DIN 433-6.4  
 T-Slot Nut V 8 St M6  
 m = 58.0 g

1 set

0.0.624.27





Firm grip for soft drinks.



## Cup Holder 8

item keeps your mug or cup within easy reach, ready for those all-important tea breaks!  
Cup Holder (diameter 84 mm) made from stainless steel wire.

## Bottle Holder 8

Keep refreshment close to hand – with the item Bottle Holder.  
Holder for bottles or cans up to 100 mm in diameter. Made from stainless steel wire.

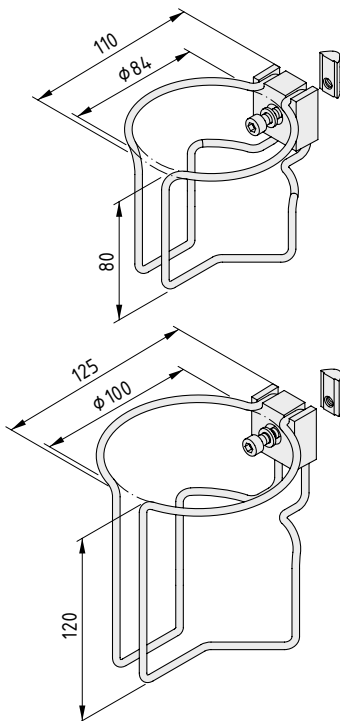

### Cup Holder 8



Wire, St, stainless  
Wire mount, PA-GF, black  
Hexagon Socket Head Cap Screw DIN 912-M6x20  
Washer DIN 433-6.4  
T-Slot Nut V 8 St M6  
m = 114.0 g

1 set

0.0.624.34

### Bottle Holder 8



Wire, St, stainless  
Wire mount, PA-GF, black  
Hexagon Socket Head Cap Screw DIN 912-M6x20  
Washer DIN 433-6.4  
T-Slot Nut V 8 St M6  
m = 140.0 g

1 set

0.0.624.33



Safe and sound.

## Tool Holder D120

Keep heavy hand tools within easy reach – with the item Tool Holder. Electric drivers or special tools are held safely and securely in the holster until they are needed. The Tool Holder comprises stainless steel wire and a flexible plastic holster with a tapered internal diameter of 90 mm to 40 mm.

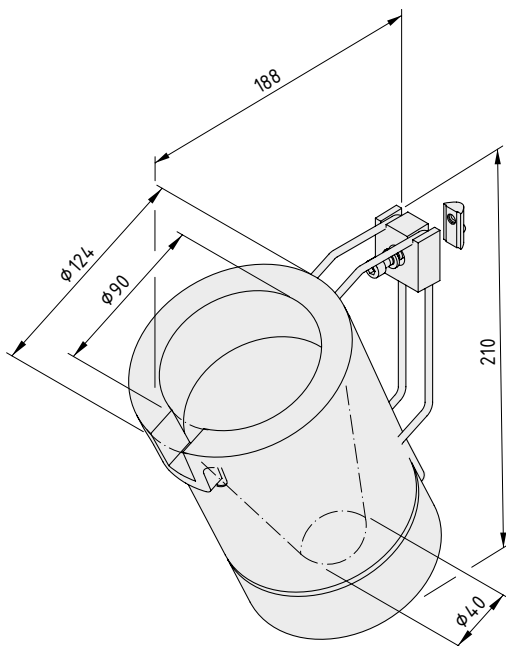

### Tool Holder D120

Tool Holder holster, PUR, black  
 Wire, St, stainless  
 Wire mount, PA-GF, black  
 Hexagon Socket Head Cap Screw DIN 912-M6x20  
 Washer DIN 433-6.4  
 T-Slot Nut V 8 St M6  
 m = 510.0 g

1 set

0.0.626.88

Magnetic attraction.



## Magnetic Holder 8

Its pull is irresistible – the item Magnetic Holder!

For securely stowing metallic objects such as spanners, etc. on the groove of the non-magnetic aluminium Profile.

Magnetic Holder 8 can be fitted into a Profile 8 groove in next to no time.

Holding force  $F = 40\text{ N}$

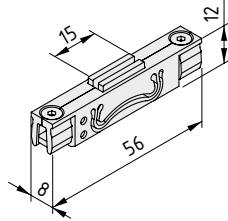

### Magnetic Holder 8



Magnet housing half 8, PA-GF, grey, similar to RAL 7042  
2 magnets 20x5x2, St, nickel-plated  
2 Magnetic Stops 8, terminal shoes, St, bright zinc-plated  
2 Countersunk Screws DIN 7991-M3x10, St, bright zinc-plated  
2 square nuts DIN 562-M3, St, bright zinc-plated  
 $m = 18.0\text{ g}$

grey, similar to RAL 7042, 1 pce.

0.0.627.86

Finding the right balance.



## Tool Balancer

The new Tool Balancers from item ensure everything is in perfect equilibrium. The retraction force is manually adjustable and an integrated securing loop is included. They can be easily adjusted to suit the reach of the operator. Simply select the Tool Balancer that is most suitable for your tools – 0.4 to 1 kg or 1 to 2 kg.

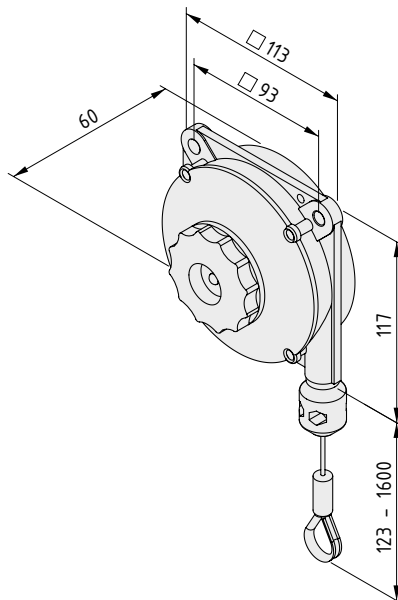

### Tool Balancer 0.4-1 kg

Die-cast aluminium  
Wire cable, diameter 2 mm, St, stainless  
m = 0.6 kg

1 pce.

0.0.631.84

### Tool Balancer 1-2 kg

Die-cast aluminium  
Wire cable, diameter 2 mm, St, stainless  
m = 0.6 kg

1 pce.

0.0.636.48



Close computer support.

Can be adjusted for various housing sizes

Retractable

Rotatable



### Work bench PC Mount

Both PC and keyboard can be safely and securely fastened with the optimum mounting devices from item.

Fasten the PC Mount for work benches below the working surface and simply place your computer into the holder.

The PC Mount can be adjusted to accommodate various housing sizes and additional pull-out rails under the table allow you to pull out and rotate their hardware. As a result, your computer stays easily accessible for maintenance and cleaning at all times.

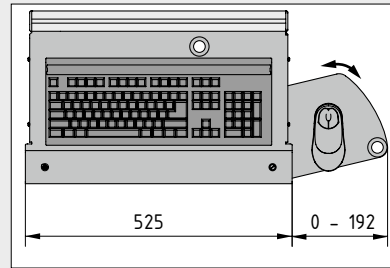

The mouse rest can be fitted to the right or left of the Keyboard Shelf.

The Keyboard Shelf holds the computer keyboard and mouse. It can be fitted securely to Pivot Arms or an area in the work bench handling zone via its screw fastening. The use of additional Telescopic Slides also allows a retractable version to be fitted underneath the working surface.

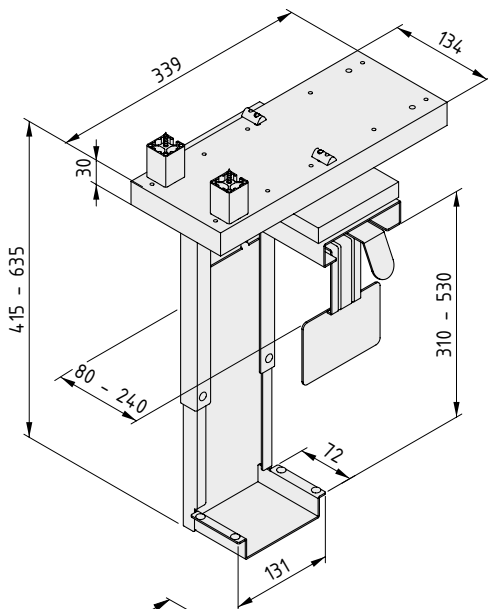

**PC Mount**

Mount with pull-out rail and rotating element, St, white aluminium  
 2 Countersunk Screws 5x60, St, bright zinc-plated  
 2 spacers, Al, natural  
 2 Button-Head Screws M6x14, St, bright zinc-plated  
 2 T-Slot Nuts 8 St M6, bright zinc-plated  
 Notes on Use and Installation  
 m = 5.8 kg

1 set	0.0.631.70
-------	------------

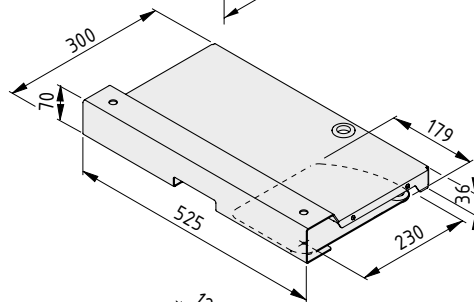

**Keyboard Shelf**

Keyboard Shelf 500x200, Al, powder-coated white aluminium  
 Mouse rest suitable for R/L fitting, folds out  
 2 cable holes 23x30x2 mm  
 Washer 6x54x2 mm  
 Book screw M4x5  
 Notes on Use and Installation  
 m = 1.8 kg

1 pce.	0.0.620.87
--------	------------

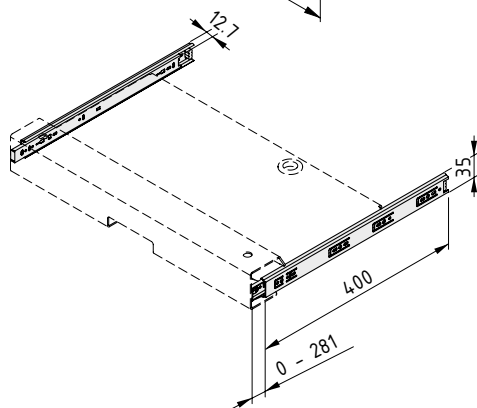

**Telescopic Slide 400 TA**

St, bright zinc-plated  
 m = 770.0 g

1 set	0.0.626.25
-------	------------

## Related products from our full range.

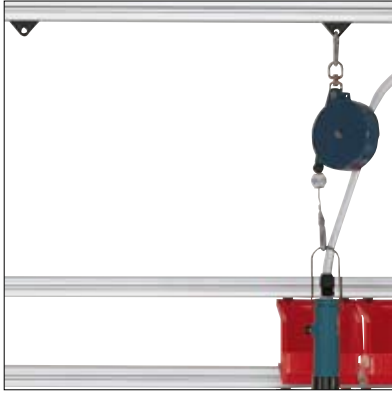

Lightweight hanger that can be moved along the profile groove and is used for suspending tools, balancers etc.

### Runner 8



black, 1 pce.

0.0.026.13

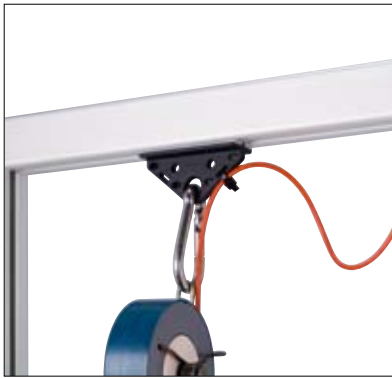

A heavy-duty Runner for Profile 8 grooves. A load of up to 200 N can be secured safely to this hanger and moved. Integrated slide inserts made of special plastic ensure that tools, balancers etc. can be moved easily, with low wear.

The corrosion-resistant Spring Hooks enable easy attachment to the Runner and rapid tool changes.

### Runner 8 80x40



1 set

0.0.618.97

### Spring Hook 60 D6



stainless, 1 pce.

0.0.619.68

### Spring Hook 80 D8



stainless, 1 pce.

0.0.619.70



Tool Holder 8 can be fitted at any point in the groove of Profiles 8. Its spring-loaded elements made of flexible plastic enclose any inserted tools and pencils and hold them securely.

### Tool Holder 8



1 set = 10 elements

0.0.474.50



Detailed descriptions of these products can be found online.

[www.item24.com](http://www.item24.com)



## Keeping everything in sight.

Practical solutions for holding your information – with innovative work bench accessories from item. Work benches are nodal points in a networked production system. They need to be able to send and receive information as integral components in a production control and material flow system. Our comprehensive range keeps your information flowing!

- 54** **Display Panel Holder 8**  
Display Panel Holder and Display Panels with black or red edging.

- 56** **Compound Material**  
Compound Material St 2 mm, multiple layers, for attaching magnets or using as a whiteboard. Available in the dimensions of your choice.
- 57** **Notice Holder A4, magnetic**  
A fitting frame for up-to-date information, with magnetic edge. Available in grey, yellow, green and red.
- 58** **Related products from our full range**

Providing information at the work bench.



## Display Panel Holder 8

The item Display Panel system ensures that safety instructions, working plans, etc. are clearly positioned and always in view at any work bench!  
Simply fit the Display Panel Holder to the profiles and add hard-wearing black or red polypropylene (PP) Display Panels as required.  
Simply insert the Display Panels into the holder.

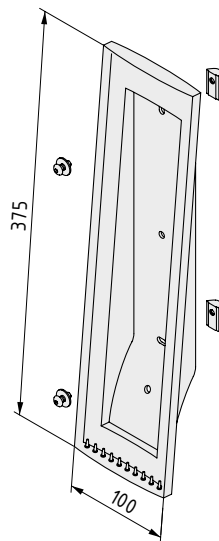

### Display Panel Holder 8



Display Panel Holder  
2 T-Slot Nuts V 8 St M5, bright zinc-plated  
2 Button-Head Screws M5x12, St, bright zinc-plated  
2 screws DIN 5021-5,3, St, bright zinc-plated  
m = 210.0 g

1 set

0.0.631.87

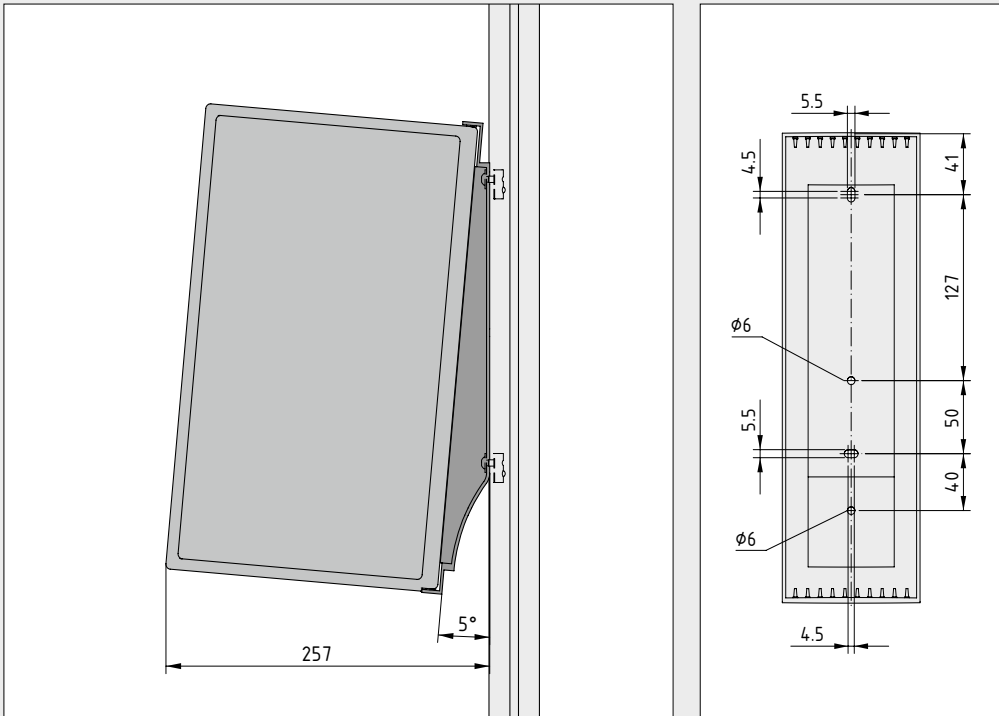

Each holder can accommodate up to 10 Display Panels. The slightly inclined positioning of the holder ensures that display panels stay open and are therefore easy to read.

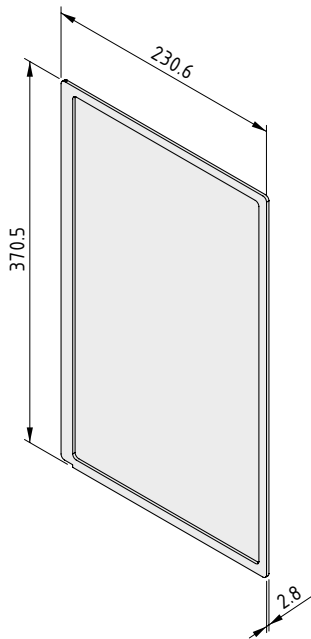

**Display Panel PP**

Format A4  
m = 50.0 g

black, 1 pce.	0.0.635.18
red, 1 pce.	0.0.636.77



The perfect backdrop.

Can be written on

Attracts magnets

## Compound Material St 2 mm

Besides being magnetic, the surface of the Compound Material can also be directly written on. Compound Material St 2 mm comprises 5 layers and is suitable for use with magnets and white-board markers.

You can also use the Compound Material as a base for the magnetic Notice Holders or for "pinning up" notices with magnets.

Available as a panel or a cut-off in the dimensions of your choice.



### TIP

Compound Material St 2 mm is an ideal and easy-to-use material for creating magnetic partitions and notice boards.

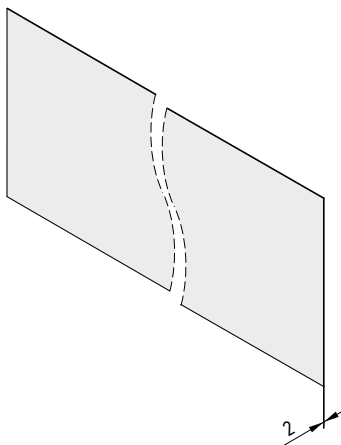

### Compound Material St 2 mm

$m = 1.70 \text{ kg/m}^2$

white, similar to RAL 9016, cut-off max. 3020x1190 mm

0.0.636.04

white, similar to RAL 9016, 1 pce. panel dimensions. max. 3050x1220 mm

0.0.633.97



### Notice Holder A4, magnetic

The new magnetic Notice Holder – important information where you need it and when you need it! These Notice Holders protect your notices and allow you to display important information on any suitable ferrous surface, such as item Compound Material St. The Notice Folders are made from hard-wearing transparent film and have a magnetic frame. Size approx. 320x232 mm. Available in grey, yellow, green and red.

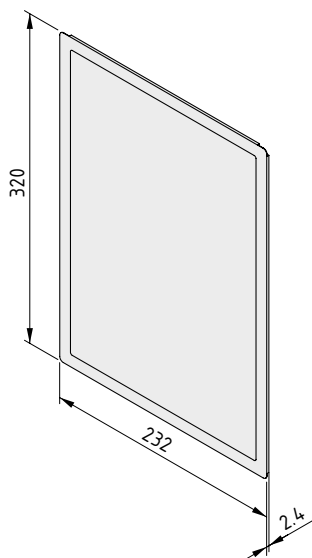

#### Notice Holder A4, magnetic

Rigid PVC film, 0.4 mm, non-reflective  
Magnetic strips  
m = 120.0 g

grey, 1 pce.	0.0.635.11
yellow, 1 pce.	0.0.636.61
green, 1 pce.	0.0.636.62
red, 1 pce.	0.0.636.63

## Related products from our full range.



Label Holder 8 160x40 is used for attaching labels to shelves, work benches and fixtures. The Label Holder takes paper labels 36 mm high that can be customised at will. The transparent strip protects the labels against soiling.

### Label Holder 8 160x40

1 set	0.0.488.70
-------	------------



The Document Holder system is used for constructing display and information panels of any size in the workplace or the training area. The panels can be attached directly to a frame construction made of aluminium profiles, e.g. to a work bench in the production area.

The spring-loaded Lid Profile firmly clamps documents and drawings and can securely hold an optional acrylic glass panel to protect documents.

### Document Holder 8 A4

1 set	0.0.476.22
-------	------------

### Document Holder 8 A3

1 set	0.0.476.23
-------	------------

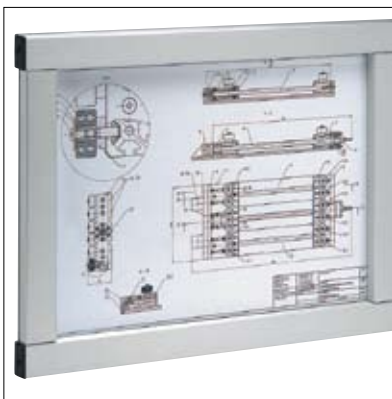

### Document Holder 8 Frame A4

1 set	0.0.476.24
-------	------------

### Document Holder 8 Frame A3

1 set	0.0.476.25
-------	------------



Detailed descriptions of these products can be found online.

[www.item24.com](http://www.item24.com)





## Systematic ESD protection.

The safe dissipation of electrostatic discharges (ESD) is a basic requirement for modern work benches. Measuring devices, production equipment and of course electronic work-piece components themselves – all of these can be damaged or destroyed by charges.

A work bench concept must take into account all the components involved in a process, make all the necessary accessories available to the operator and involve the employees themselves.

-  **60** ESD Wristband DK10  
For ensuring a safe contact between operators and their item work benches.

-  **60** ESD Connection Cable DK10 and Central Connection 8  
For connecting a Wristband or working surface to the earth potential. Available as a straight or coiled cable with ring connector or snap fastener.  
ESD Central Connection for creating an equipotential bond between ESD components and the profile structure of the work bench.

-  **62** ESD Table Mat DK10  
For localised ESD protection on the working surface and connected to an ESD Central Connection or Earthing Plug.

-  **62** ESD Earthing Plug and Earthing Terminal  
Earthing Plug and Earthing Terminal with 3x10 mm snap fastener connectors.

-  **64** Related products from our full range



Safe and secure.



## ESD Wristband DK10

The item ESD Wristband is an essential component for any work bench.

As employees both carry and transfer charges, it is crucial to incorporate them into any ESD concept. The ESD Wristband provides effective protection against electrostatic build-up at work benches and links the operator with the potential of the work bench.

The nylon Wristband with snap fastener can be connected to the ESD Earthing Terminal or the ESD Earthing Plug using a connection cable.

Discharge resistance: 1 MΩ

## ESD Connection Cable DK10, coiled

Making the connection – the ESD Connection Cable and ESD Central Connection from item.

Choose the best connection cable for your needs. Straight cables (with or without ring connector) and coiled cables are available.

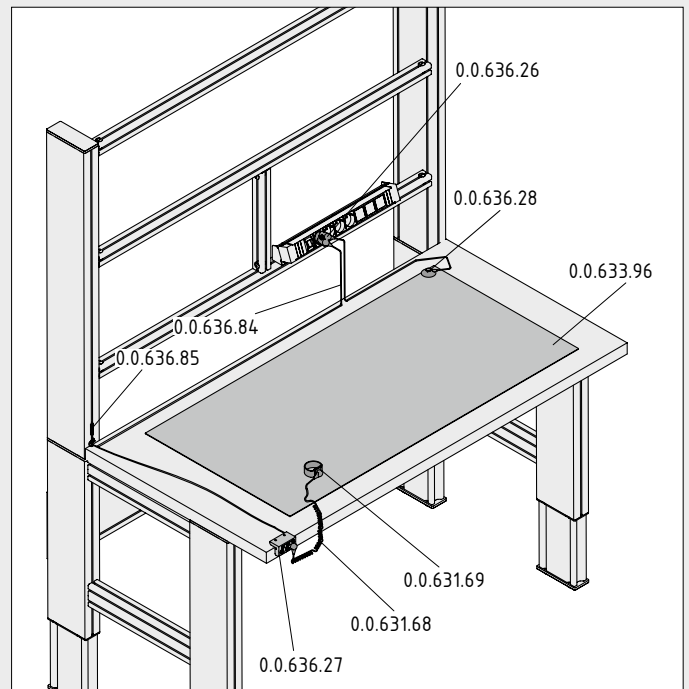
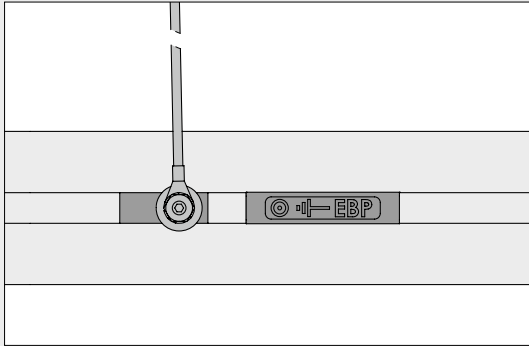
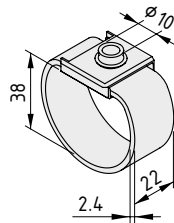

Illustration of an ESD-safe work bench.



The ESD Central Connection with T-Slot Nut and grub screw is fitted to the profile frame of the work bench and used for the connection and potential equalisation of various ESD elements (table top, Table Mat).



**ESD Wristband DK10**



Fabric, elastic, hypoallergenic, black  
With snap fastener DK10  
m = 11.0 g

1 pce.

0.0.631.69

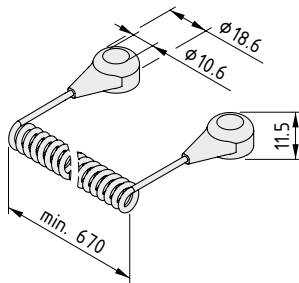

**ESD Connection Cable DK10, coiled**



Coiled cable, diameter 2.4 mm, black  
Suitable for earthing people  
Resistance 1 MΩ  
m = 27.0 g

1 pce.

0.0.631.68

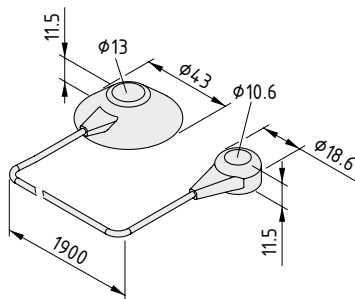

**ESD Connection Cable DK10, straight**



Cable, straight, diameter 2.4 mm, black  
m = 47.0 g

1 pce.

0.0.636.28

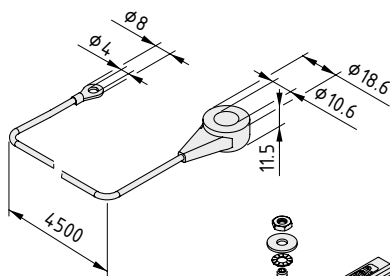

**ESD Connection Cable DK10 - Ring Connector 4 mm**



Cable, straight, diameter 2.4 mm, black  
m = 65.5 g

1 pce.

0.0.636.84

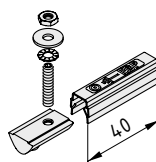

**ESD Central Connection 8**



T-Slot Nut V 8 St M4  
Grub screw M4x20  
Special washer, washer, lock nut  
Central Connection labelling  
m = 20.0 g

1 pce.

0.0.636.85

## Safety mat.



### ESD Table Mat DK10

Special protection for your components – the ESD Table Mat from item. The ESD Table Mat is made from composite material with an abrasion-resistant synthetic rubber surface and has two snap fasteners for attaching a connection cable.

The mat can be connected to additional ESD equipment from item such as fastening elements on the profile (ESD Central Connection), the ESD Earthing Terminal and the ESD Earthing Plug.

### ESD Earthing Plug , 3 x DK10 ESD Earthing Terminal, 3 x DK10

Make connections fast – with the ESD Earthing Plug and ESD Earthing Terminal!

The item ESD Earthing Terminal has three connections (10 mm snap fasteners) for connection cables and serves as a "collection point" for the dissipation of electrostatic charges in the work bench handling area. The device is fitted below the working surface.

The item ESD Earthing Plug also has three connections (10 mm snap fasteners). It is inserted in a power socket (German domestic standard) and safely transfers charges to the earth potential of the power supply system.

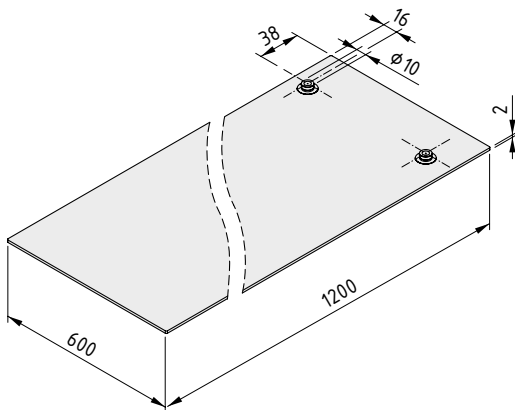

**ESD Table Mat DK10**



Upper, dissipative  
Lower, conductive  
Synthetic rubber, grey/black  
m = 1.8 kg

1 pce.

0.0.633.96

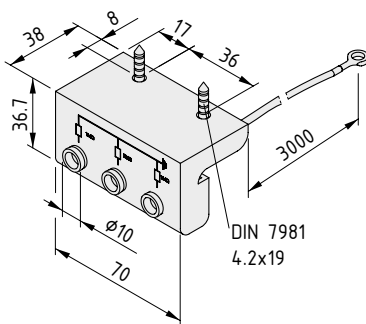

**ESD Earthing Terminal, 3 x DK10**



Earthing Terminal, yellow  
Line, diameter 2.4 mm, black  
Discharge resistance 1 MΩ  
m = 70.0 g

1 pce.

0.0.636.27

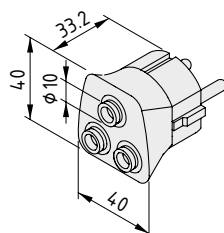

**ESD Earthing Plug, 3 x DK10**



Dummy plug, yellow  
Discharge resistance 1 MΩ  
m = 27.0 g



1 pce.

0.0.636.26

## Related products from our full range.



Parts Containers made from special antistatic plastic for holding parts that are especially sensitive to ESD.

<b>Parts Container 80x40 antistatic</b>	<b>ESD</b> 
black, 1 pce.	0.0.432.76
<b>Parts Container 120x40 antistatic</b>	<b>ESD</b> 
black, 1 pce.	0.0.432.77
<b>Parts Container 160x80 antistatic</b>	<b>ESD</b> 
black, 1 pce.	0.0.432.78



Ergonomic Arm Rest for rounding table edges and avoiding impact points. The antistatic surface prevents the build-up of electrostatic charges.

<b>Arm Rest antistatic</b>	<b>ESD</b> 
1 set	0.0.465.10



Detailed descriptions of these products can be found online.

[www.item24.com](http://www.item24.com)



## Work bench interlinking

The flexible structures of group work benches and production islands support integrated checking procedures, independent process control and high-productivity manufacturing. The modular design of the new item work benches provides the ideal basis for delivering cutting-edge workplace organisation.



## Work bench interlinking

Today, flexible, cost-effective and ergonomic work benches are more important than ever in the value-added chain. The new item components for equipping and interlinking work benches are both modern and versatile. And a solid investment for the future!



Discover the flexibility offered by item components for interlinking manual work benches. Detailed information on Castor Rails and guide elements for transporting workpieces and moving goods can be found in our Spring 2010 New Products catalogue. Profiles and fastening elements from Line D30 (New Products – Autumn 2010) can be used to create mobile intermediate storage shelves based on the FIFO principle for the reduction of stock levels (Kanban). They are also ideal for enhancing existing work benches.

Having difficulty finding something in our New Products catalogue? Our Comprehensive Catalogue for the MB Building Kit System contains the full range of system elements that we offer. Discover the unlimited options for your requirements.



# Configure your work bench system

Submit enquiry by fax: +49 212 6580-310  
E-mail: info@item.info

Company: \_\_\_\_\_

Address: \_\_\_\_\_



Contact person: \_\_\_\_\_

Telephone: \_\_\_\_\_

Fax: \_\_\_\_\_

E-mail: \_\_\_\_\_

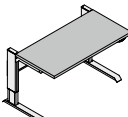
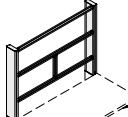
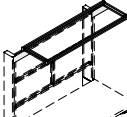
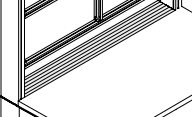
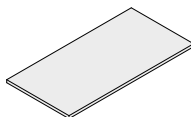
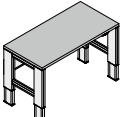
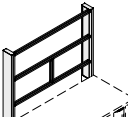
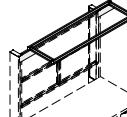
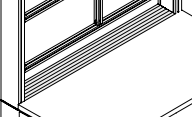
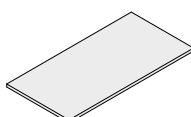
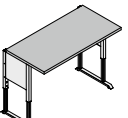
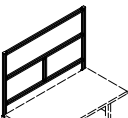
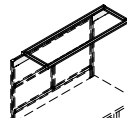
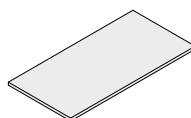
Comments: \_\_\_\_\_

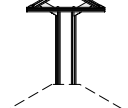
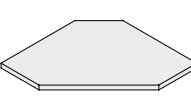
Work Bench E	Upright	Overhang	Cable Duct	Table Top	
					
Width <input type="checkbox"/> 1200 <input type="checkbox"/> 1500 <input type="checkbox"/> 1800	Depth <input type="checkbox"/> 600 mm <input type="checkbox"/> 750 mm ____ pcs.	<input type="checkbox"/> Upright	<input type="checkbox"/> Overhang (Upright required)	<input type="checkbox"/> Cable Duct E	<input type="checkbox"/> plastic coated, 25 mm <input type="checkbox"/> high pressure laminate, 30 mm <input type="checkbox"/> high pressure laminate, ESD, 30 mm <input type="checkbox"/> beech multi-ply, 40 mm
Work Bench 4 E	Upright	Overhang	Cable Duct	Table Top	
					
Width <input type="checkbox"/> 1200 <input type="checkbox"/> 1500 <input type="checkbox"/> 1800	Depth <input type="checkbox"/> 600 mm (Upright required) <input type="checkbox"/> 750 mm ____ pcs.	<input type="checkbox"/> Upright	<input type="checkbox"/> Overhang (Upright required)	<input type="checkbox"/> Cable Duct E (Upright required)	<input type="checkbox"/> plastic coated, 25 mm <input type="checkbox"/> high pressure laminate, 30 mm <input type="checkbox"/> high pressure laminate, ESD, 30 mm <input type="checkbox"/> beech multi-ply, 40 mm
Work Bench F	Upright	Overhang		Table Top	
					
Width <input type="checkbox"/> 1200 <input type="checkbox"/> 1500 <input type="checkbox"/> 1800	Depth <input type="checkbox"/> 600 mm <input type="checkbox"/> 750 mm ____ pcs.	<input type="checkbox"/> Upright	<input type="checkbox"/> Overhang (Upright required)	<input type="checkbox"/> plastic coated, 25 mm <input type="checkbox"/> high pressure laminate, 30 mm <input type="checkbox"/> high pressure laminate, ESD, 30 mm <input type="checkbox"/> beech multi-ply, 40 mm	
Work Bench TRIGO	Upright			Table Top	
					
Width x Depth <input type="checkbox"/> 1100 x 600 x 780 mm <input type="checkbox"/> 1315 x 750 x 930 mm ____ pcs.	<input type="checkbox"/> Upright with Overhang			<input type="checkbox"/> plastic coated, 25 mm <input type="checkbox"/> high pressure laminate, 30 mm <input type="checkbox"/> high pressure laminate, ESD, 30 mm <input type="checkbox"/> beech multi-ply, 40 mm	

## Attachments and accessories

Accessory components for self-assembly are supplied with the table.

Table accessories	Power and data supply	Lighting	
____ pcs. Drawer Unit S2 H283 ____ pcs. Drawer Unit S3 H383 ____ pcs. Drawer Unit Adapter Set, table depth 600 ____ pcs. Drawer Unit Adapter Set, table depth 750 ____ pcs. Foot Rest 450x400 ESD	____ pcs. Distribution Strip ____ pcs. Distribution Strip Insert RJ45 ____ pcs. Distribution Strip Insert USB ____ pcs. Distribution Strip RCD Unit ____ pcs. Multi-Socket Power Strip, 8 outlet, 19", with conventional power cord ____ pcs. Multi-Socket Power Strip, 5 outlet, with system plug ____ pcs. Multi-Socket Power Strip, 5 outlet, with conventional power cord ____ pcs. Multi-Socket Power Strip Angle Fastening Set 70° ____ pcs. Connecting Cable, Socket / Earthed Plug ____ pcs. Adapter, Socket / Plug	____ pcs. Compressed Air Manifold ____ pcs. Flexible Conduit E ____ pcs. Modular Cable Duct 160KW (for Table F)	
		____ pcs. LED Illuminated Magnifier ____ pcs. LED Machine Light Fitting ____ pcs. Lamp 35W ____ pcs. Lamp 35W with Flexible Tube ____ pcs. Electronic Transformer 105W ____ pcs. Light Fitting 55W, 230V	
		 <p>Now you can plan your work bench online, too.</p> <p><a href="http://workbench.item24.com">workbench.item24.com</a></p>	
Pivot Arm	Tool handling	Information provision	ESD components
____ pcs. Pivot Arm 8 370 light ____ pcs. Double Pivot Arm 8 695 light ____ pcs. Double Pivot Arm 8 695 heavy-duty ____ pcs. Parts Container 80x40 ____ pcs. Parts Container 120x40 ____ pcs. Parts Container 160x80 ____ pcs. Monitor Adapter 8 VESA 75-100 PA ____ pcs. Frame Profile 8 40x20 ____ pcs. Corner-Fastening Set Frame 8 40x20 ____ pcs. Retaining Cord D6	____ pcs. Hook 8 40x20 ____ pcs. Hook 8 40x40 ____ pcs. Hook 8 80x20 ____ pcs. Holder 8 240x80 ____ pcs. Holder 8 D80 ____ pcs. Cloth Holder 8 ____ pcs. Cup Holder 8 ____ pcs. Bottle Holder 8 ____ pcs. Tool Holder D120 ____ pcs. Magnetic Holder 8 ____ pcs. PC Mount ____ pcs. Keyboard Shelf ____ pcs. Telescopic Slide 400 TA ____ pcs. Tool Balancer 0.4-1 kg ____ pcs. Tool Balancer 1-2 kg ____ pcs. Runner 8 ____ pcs. Runner 8 80x40 ____ pcs. Tool Holder 8 ____ pcs. Spring Hook 60 D6 ____ pcs. Spring Hook 80 D8	____ pcs. Display Panel Holder 8 ____ pcs. Display Panel PP black, 1 pce. ____ pcs. red, 1 pce. ____ pcs. Compound Material St 2 mm ____ pcs. Dimensions: _____ ____ pcs. Notice Holder A4, magnetic ____ pcs. red ____ pcs. green ____ pcs. yellow ____ pcs. grey ____ pcs. Document Holder 8 Frame A4 ____ pcs. Document Holder 8 Frame A3 ____ pcs. Document Holder 8 A4 ____ pcs. Document Holder 8 A3 ____ pcs. Label Holder 8 160x40	____ pcs. ESD Wristband DK10 ____ pcs. ESD Connection Cable DK10, coiled ____ pcs. ESD Connection Cable DK10, straight ____ pcs. ESD Connection Cable DK10 - Ring Connector 4 mm ____ pcs. ESD Central Connection 8 ____ pcs. ESD Table Mat DK10 ____ pcs. ESD Earthing Terminal, 3 x DK10 ____ pcs. ESD Earthing Plug, 3 x DK10 ____ pcs. Parts Container 80x40 antistatic ____ pcs. Parts Container 120x40 antistatic ____ pcs. Parts Container 160x80 antistatic ____ pcs. Arm Rest antistatic



## Index.

### Tables

Work Bench E	10
Work Bench 4 E	12
Work Bench F	14
Work Bench TRIGO F	16
Table Tops	18

### Table accessories

Drawer Unit S2 H283	21
Drawer Unit S3 H383	21
Drawer Unit Adapter Set, Table Depth 600	21
Drawer Unit Adapter Set, Table Depth 750	21
Foot Rest 450x400 ESD	21

### Power and data supply

Distribution Strip	24
Distribution Strip Insert RJ45	25
Distribution Strip Insert USB	25
Distribution Strip RCD Unit	25
Multi-Socket Power Strip Angle Fastening Set 70°	25
Connecting Cable, Socket / Earthed Plug	25
Adapter, Socket / Plug	25
Multi-Socket Power Strip, 8 outlet, 19", with conventional power cord	27
Compressed Air Manifold	28
Flexible Conduit E	29
Multi-Socket Power Strip, 5 outlet, with system plug	30
Multi-Socket Power Strip, 5 outlet, with conventional power cord	30
Catch 160 KW	30

### lighting

LED Illuminated Magnifier	32
LED Machine Light Fitting	33
Light Fitting 55W, 230V	34
Connecting Cable, Socket / Earthed Plug	34
Lamp 35W	34
Lamp 35W with Flexible Tube	34
Electronic Transformer 105W	34

### Pivot Arms

Pivot Arm 8 370 light	37
Double Pivot Arm 8 695	37
Double Pivot Arm 8 695 heavy-duty	38
Parts Container 80x40	39
Parts Container 120x40	39
Parts Container 160x80	39
Monitor Adapter 8 VESA 75-100 PA	39
Frame Profile 8 40x20	39
Corner-Fastening Set Frame 8 40x20	39
Retaining Cord D6	39

### Tool handling

Hook 8 40x20	43
Hook 8 40x40	43
Hook 8 80x20	43
Holder 8 240x80	44
Holder 8 D80	44
Cloth Holder 8	45
Cup Holder 8	46
Bottle Holder 8	46
Tool Holder D120	47
Magnetic Holder 8	48
Tool Balancer 0.4-1 kg	49
Tool Balancer 1-2 kg	49
Telescopic Slide 400 TA	51
PC Mount	51
Keyboard Shelf	51
Runner 8	52
Runner 8 80x40	52
Spring Hook 60 D6	52
Spring Hook 80 D8	52
Tool Holder 8	52



## Information provision

Display Panel Holder 8	54
Display Panel PP	55
Compound Material St 2mm	56
Notice Holder A4, magnetic	57
Label Holder 8 160x40	58
Document Holder 8 A4	58
Document Holder 8 A3	58
Document Holder 8 Frame A4	58
Document Holder 8 Frame A3	58

## ESD components

ESD Wristband DK10	61
ESD Connection Cable DK10, straight	61
ESD Connection Cable DK10, coiled	61
ESD Connection Cable DK10 - Ring Connector 4mm	61
ESD Central Connection 8	61
ESD Table Mat DK10	63
ESD Earthing Terminal, 3 x DK10	63
ESD Earthing Plug, 3 x DK10	63
Parts Container 80x40 antistatic	64
Parts Container 120x40 antistatic	64
Parts Container 160x80 antistatic	64
Arm Rest antistatic	64

## Patents

Any copying of protected products is a violation of rights and, as such, shall be liable to compensation. Data and illustrations in this catalogue do not discharge the user from the obligation to carry out his own checks to determine whether the industrial property rights of third parties are infringed.

## Product liability

item shall be liable, within the framework of the applicable legal provisions, for the promised characteristics of the products shown in this catalogue. Any claims for liability above and beyond such - in particular relating to products created by third parties using products included in this catalogue - are expressly excluded.

## Conditions of use

The products in the item MB Building Kit System are suitable for use in dry conditions and over the temperature range -20°C to +70°C. item must be consulted where products are to be used for applications outside these limits.

## Conformity with Directive 2002/95/EC ("RoHS")

item has made a voluntary undertaking to refrain from using hazardous substances as defined in Directive 2002/95/EC in the products it sells, irrespective of their subsequent purpose which, in the majority of cases, does not fall under this Directive. As a result, the products listed in this catalogue comply with Directive 2002/95/EC.

Technical modifications and errors reserved.

All rights reserved. Use of texts and illustrations or reprints of any kind only permitted with our prior written consent. This applies in particular to reproduction, translation or use in electronic systems.

**item** is a registered trademark of item Industrietechnik GmbH.

© item Industrietechnik GmbH 2010

Up-to-date information is available online



## Concept, design and realisation

item Industrietechnik GmbH,  
Technical Documentation Department

## Photographs

item Industrietechnik GmbH

Your distribution and service partner

**item**

item Industrietechnik GmbH  
Friedenstrasse 107-109  
42699 Solingen  
Germany

Phone +49 212 6580 300  
Fax +49 212 6580 310

info@item.info  
www.item.info

Your ideas are worth it.